



Fuse Switch Units & Switch Fuse Units





G E Power Controls Fuse Switch Units & Switch Fuse Units

G E Power Controls range of 415 Volts Fuse Switches/Switch Fuses are available in Cast Iron/Sheet Steel enclosures from 32 Amps to 800 Amps to cater to the needs of various industrial applications. All the ratings are ISI certified and are designed to accept G E Power Controls ISI certified HBC fuselinks.

Combination Fuse Switch Units in Cast Iron Enclosure - Type CH

Totally enclosed, fully shrouded, cast iron clad units of robust construction designed to meet most adverse conditions in service. Casting coated with unicoat paint.

ON/OFF indication.

Two external earthing terminals.

Double break isolation arrangement ensuring complete isolation of fuselinks when the unit is in the 'OFF' position.

Quick make and quick break mechanism independent of the speed of the operator.

All current carrying parts are hard silver plated.

All fixed contacts housed in the most modern insulated base and shrouds.

All units accept G E Power Controls Ltd., HBC (High Breaking Capacity) fuselinks as per details given in Technical Data.

All units are provided with bolted type neutral links with facility to disconnect the neutral easily.

For cabling convenience, moving contact assembly can be easily removed in 100Amps to 315 Amps ratings after depressing a red cam lever which will relieve the assembly of the spring pressure.

Units are suitable to receive ferrule (bottle) type socket. It is recommended that crimped type socket are used in preference to solder type. For 63 Amps rating aluminium cables may be pinched directly as per procedure detailed under installation and maintenance instructions.

Interlocks are provided to ensure that the lid cannot be opened until the switch is in the 'OFF' position and that the unit cannot be switched 'ON' unless the lid is properly closed. It is, however, possible for a competent examiner to operate the switch with the lid open by releasing the interlock.

All ratings are ISI certified to IS:4064-1978.

Range 63A to 315A, 3P

Four pole versions are available from 100A to 315A.

Higher rating of CFS units are in sheet steel enclosure, covered separately.

Combination Fuse Switch Units in Sheet Steel Enclosure - Type CHD

Salient Features

Totally enclosed, fully-shrouded, sheet steel-clad units in two basic frame sizes.

ON/OFF flag indication.

Two external earthing terminals.

Quick-make, quick-break mechanism, independent of the speed of operator.

Double-break isolation arrangement ensuring complete isolation of fuse links when unit is in 'OFF' position.

All units provided with phase/phase, phase/earth barriers for extra safety.

All units provided with bolted-type neutral link, with facility to disconnect neutral easily.

All current-carrying parts are hard silver-plated.

Terminals designed to take aluminium/copper flats of appropriate size to which cable sockets can be fitted.

ISI certified (IS : 4064 - 1978).





Fuse Switch Units & Switch Fuse Units

Switch fuse units in sheet steel enclosure



Fully interlocked, sheet steel enclosure metal treated for rust prevention and coated with unicoat paint.

ON/OFF indication.

Two external earthing terminals.

Quick make and quick break mechanism independent of the speed of the operator.

All current carrying parts are hard silver plated.

Fully shrouded fixed contacts enclosed in phenolic moulded base and suitable for aluminium conductor cables.

High grade phenolic moulded fuse holders for incorporating G E Power Controls make HBC fuselinks as per details given in Technical Data.

All units are provided with bolted type neutral links with facility to disconnect the neutral easily.

Switch blades clamped on solid insulation in preference to metallic shaft with insulation sleeving.

Crimped type cable sockets are recommended for cabling as a general rule. However, direct pinching of cables is also possible for the units provided proper precaution is taken as per details under installation and Maintenance instructions.

Conduit knock-outs at top and bottom for 32 Amps and 63 Amps.

Interlocks are provided to ensure that the lid cannot be opened until the switch is in the 'OFF' position and that the unit cannot be switched 'ON' unless the lid is properly for a competent examiner to operate the switch with the lid open by releasing the interlock.

Generous space for wiring, inspection and maintenance.

All ratings are ISI certified to IS: 4046-1978.

Dimensions in mm

LP - 32/63A

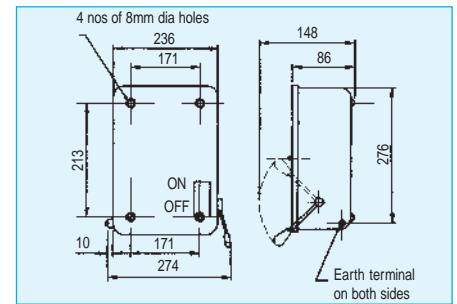

CH - 63 A

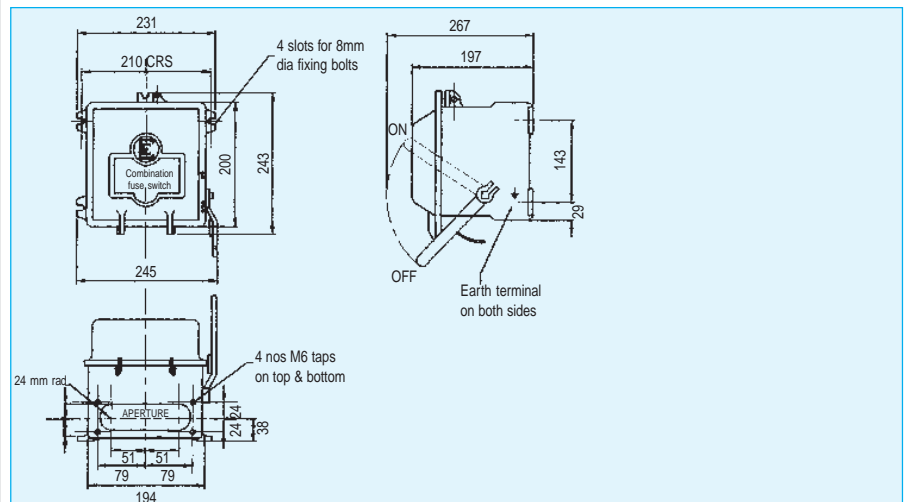

CH - 100A/200A/315A(See table for dimensions)

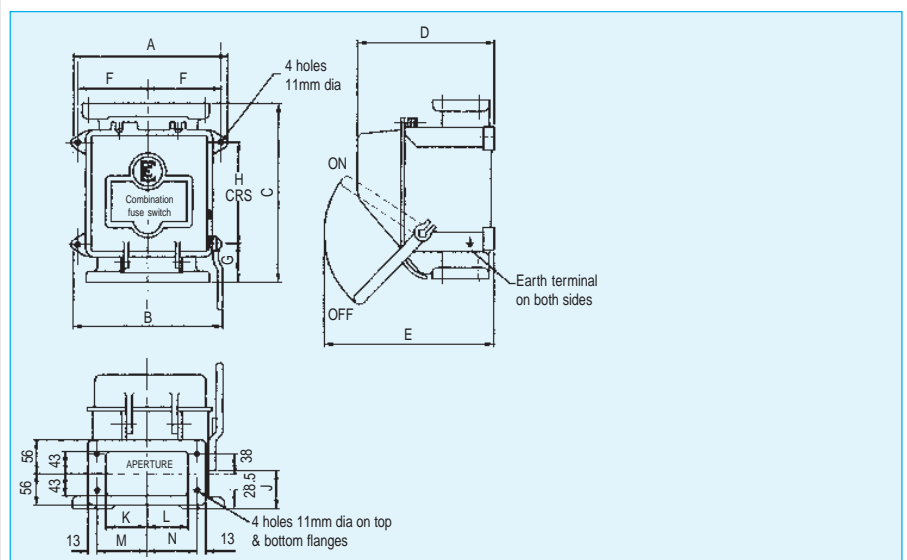

Dimensions in mm

Rating Amp	No. of poles	A	B	C	D	E	F	G	H	J	K	L	M	N
100	TP/TPN	286	296	381	248	305	129	83	216	59	90	81	110	100
200	TP/TPN	330	340	406	280	341	149	83	241	69	108	102	127	121
315	TP/TPN	450	460	406	280	397	210	108	216	72	162	162	181	181



Fuse Switch Units & Switch Fuse Units

Dimensions in mm (CHD)

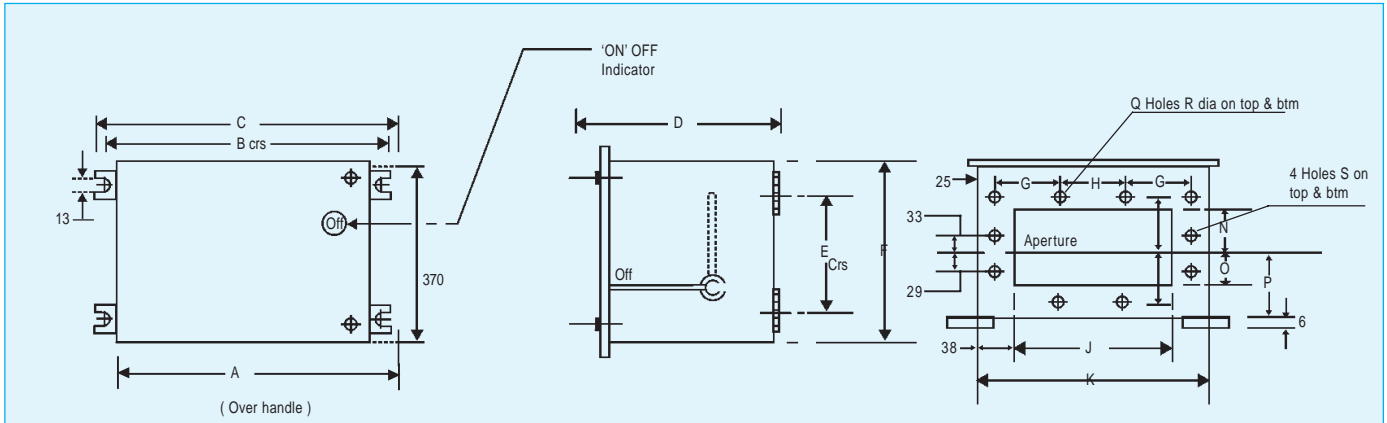

Ratings	A	B	C	D	E	F	G	H	I	J	K	L	M	N	O	P	Q	R	S
400/500A	500	505	540	357	328	360	200	-	-	375	451	83	92	74	66	104	2	7	12.7
630/800A	620	625	661	416	323	355	174	174	174	496	572	195	103.5	182.5	90.5	128.5	6	9	11

Technical particulars - LP / CH

Type	LP 32	LP 63	CH 63	CH 100	CH 200	CH 315
Nominal Rating in Amps at 415 V 50 Hz	32	63	63	100	200	315
Rating with solid copper links in place of fuselinks @	-	-	100	200	300	400
Rated insulation voltage (V)	600	600	600	600	600	600
Fuselinks (Type)	TIA/TSA	TIA/TSA TIS/TSS	TIA/TSA TIS/TSS	TCP/TSD	TC/TF/TSDC TSF	TC/TF/TSDC TKF/TSF/TSK
Type of enclosure	Sheet Steel	Sheet Steel	Cast Iron	Cast Iron	Cast Iron	Cast Iron
Net Weight (in Kgs) without fuselinks (approx)	3.8	4.25	11.0	26.5	34.5	40.5
Max. size of Al cable (in sq.mm)	16	35	35	70	185	240
Min. size of Al cable (in sq. mm)	4	6	6	For use with Cable Sockets		
Termination details	6.35 mm dia.bore	8.7 mm dia. bore	9.5 mm dia. bore	7.5 mm dia. bore	13.5 mm dia. bore	16.5 mm dia. bore
Short circuit withstand capacity (rms) in kA (nominal)*	46	46	46	46	46	46
Making Current Capacity (peak) in kA (nominal)*	105	105	105	105	105	105

@ Special termination arrangement for accommodating higher size of cables required.

* With fuselinks fitted, actual test values are higher than these figures.

Technical particulars - CHD

	CHD 400	CHD 500	CHD 630	CHD 800
Nominal Rating in Amps at 415 V 50 Hz	400	500	630	800
Short time withstand capacity (rms) in kA (nominal)	50	50	50	50
Making current capacity (peak) in kA (nominal)	105	105	105	105
Terminal details in mm	31.7 x 6.3 flats	38 x 6.3 flats	50.8 x 6.3 flats	63.5 x 9 flats
Fuselinks (Type)	TSMS/TSL/TTS	TSMS/TSTS TSL/TTS	TSMS/TSTS TSL/TTS	TSMS/TSTS TSL/TTS
Net Weight (in Kgs) without fuselinks (approx)	35	40	45	48



Fuse Switch Units & Switch Fuse Units

Safe Clip Switch & Switch-Fuse Units

GE Power Controls presents the safe-clip range of surface mounted sheet-steel clad switches and switch fuse units for better isolation, control and protection of electrical distribution circuits in Industrial and commercial establishments.

Quick "Make and Break" action.

Switch fuse units take HBC fuse links (80 kA).

Suitable for motor duty application.

Fully shrouded fuse holders for extra safety.

Front operation with positive ON-OFF indication.

Side by side mounting possible.

Easy access for cabling.

Tested to IS 13947-3.

Robust construction with pleasing aesthetics.

Scratch-Proof, powder coated semi-gloss grey finish.

Door-interlock and pad-locking of handle in "OFF" position.

Range:

20 and 32A-415V AC SPN, DP & TPN
Incorporating "safeclip" type fully shrouded Fuseholders.

Specification:

Designed and tested in accordance with IS 13947-3 Certified upto 80 kA fused short circuit rating when fitted with appropriate HBC fuselinks.

Construction:

Sturdy, powder coated sheet-steel enclosure provides IP42 degree of protection. A detachable hinged door fitted with gaskets opens within the width of the units. Removable gland plates with 3 conduit knockouts are provided at the top and bottom sides of the enclosure.

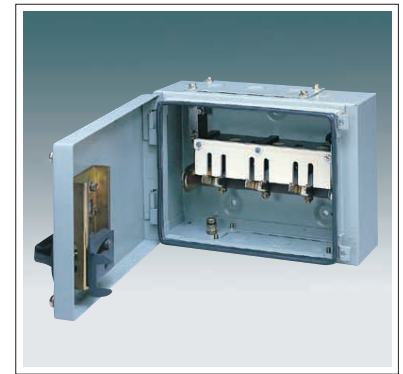

Technical Data

	20A	32A
Motor circuit ratings (AC 23 A category at 415 V AC)	5.5 Kw (7.5 HP)	11 Kw (15 HP)
Rated thermal current	20 A	32A
Rated operational Voltage	415 V AC	415 V AC
Type of fuselinks for SFU	SS	NS
- Short time withstand current (1 sec)	700A	1200A
- Rated insulation voltage	660 V AC	660 V AC

Selection

Rating A	Switch Fuse Units			Switches	
	SPN	DP	TPN	DP	TPN
20	WMSF 201 N	WMSF 202	WMSF 203 N	WMS 202	WMS 203 N
32	WMSF 321 N	WMSF 322	WMSF 323 N	WMS 322	WMS 323 N

Cabling

Rating A	Diameter of Conduit		Terminals accommodate cable up to:	
	Outer mm	Centre mm	Incoming mm ²	Outgoing mm ²
20	21	26	16	16
32	21	26	16	16

Dimensions

Rating A	Type	Dimensions in millimeters							
		A	B	C	D	E	F	G	H
20	Switch	193	84	111	181	169	133	95	54.5
	Switch Fuse	193	84	181	251	239	133	95	54.5
32	Switch	245	114	116	185	173	139	101	65.5
	Switch Fuse	245	114	209	279	267	139	101	65.5
63	Switch	340	140	185	267	255	196	126	100
	Switch Fuse	340	140	290	362	350	196	126	100

Dimensions in mm

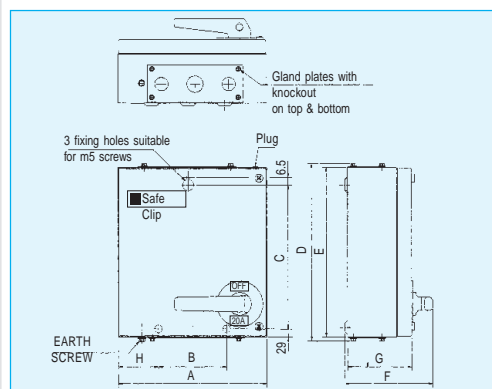



Fuse Switch Units & Switch Fuse Units

Installation & Maintenance Instructions

- The units are designed for use with HBC fuselinks only. If wires are wrapped across the terminals in place of HBC fuselinks, the units may explode under fault conditions and cause damage and danger to personnel.
- It is recommended in the users' interest that replacement fuselinks should be purchased from Authorised Dealers/Stockists only. A list of Authorised/Dealers/Stockists is available at our Regional Offices.
- It is recommended that blown HBC fuselinks are broken to pieces to avoid rewiring by spurious traders.
- Best results are obtained when a crimped type socket or soldering socket is used with aluminium cables. However, in lower ratings, there is a need for quick connection for temporary supplies, etc. Hence, units of rating upto 63 Amps are suitable to receive aluminium cables directly. When pinching the conductor directly in the terminal bore, the following procedure should be adopted for trouble-free operation:
 - (a) The individual strands should be fanned out and cleaned by wirewool or emery paper. Then the cleaned surface should be coated with a thin layer of Oxide inhibiting grease (Indian Oil type Mobile Grease MPS).
 - (b) The cable should be pinched in the terminal using the right size of screw driver for the grub screws and tightened fully. Overtightening with leverage or by use of a bigger screw driver should be avoided.
 - (c) Once in 6 months, the tightness should be checked with the right size of screw driver.
 - (d) If the conductors are disturbed from the terminal bore, It is necessary to remake the connection starting from the first step.



GE Power Controls