



High Voltage HBC Fuselinks





Type 'K' high voltage HBC fuselinks

With Dimensions to BS2692/IEC282

For use in oil to protect distribution circuits

Voltage Range 7.2kV to 12 kV
Current Range 5A to 120A

GE Power Controls range of H.V. HBC fuse links meet the dimensional requirements of BS2692-1986/IEC282-1994. These fuselinks also conform to IS 9385-Part 1-1979.

The fuse links are particularly suitable for fitting into H.V. ring main units.

This range may also be used in air-details of free air ratings are available on request.

A.C. short circuit performance

The maximum values of breaking capacity quoted are test values which may be limited by test station capability or the economics of testing. Generally the fuse link capability will be considerably higher and no practical limit is imposed on these fuse links for maximum breaking capacity under service conditions.

Low overcurrent performance

Excellent performance is provided under low overcurrent conditions. For the majority of ratings the minimum breaking current of the fuse link is between 2 and 3 times the rated current of the fuse link. This is made possible by the use of low melting point alloy which is applied to the centre of the elements thus ensuring that unacceptable temperatures are not reached during the prolonged pre-arcing period. The striker functions normally for all currents down to minimum melting current.

Where the H.V. fuse link co-ordinates with an over current protective device, for example, expulsion fuse or overload relay, then the minimum breaking current must be lower than the intersection of the prospective time/current characteristics.

Where instantaneous striker operated tripping of H.V. fuse switch combinations is employed then the minimum breaking current of the H.V. fuse link must be less than the maximum interrupting current of the associated switch.

It should be stressed that use of a fuselink having too high a value of minimum breaking current, could under certain circumstances, result in disruptive failure of the fuselinks and consequent damage, arising out of fuselink clearing faults below the minimum breaking current.

Characteristics

The time/current characteristics relate to mean pre-arcing time and are accurate to within a manufacturing tolerance of $\pm 10\%$ related to current.

The cut-off current characteristics show the maximum peak current a given fuse link will permit for various fault currents.

The minimum pre-arcing I^2t values given are for adiabatic conditions and in service pre-arcing values will normally be higher.

The total I^2t values given are obtained during tests under the most onerous conditions. They are particularly affected by applied voltage in and in service the values will generally be much less than those quoted. Because the total I^2t / prospective current characteristic tends towards a constant value, the figures quoted will also apply to prospective current greater than the maximum tested breaking capacity.

Arc voltage

The overvoltage produced by the fuselink during the arcing period is limited by values in the appropriate standards. Type K fuselinks have maximum values well within the standard and can thus generally be used at a voltage level one step down in the table listed here. For example the 12kV class may be used on 7.2kV systems and short circuit tests have been conducted to verify that the arc voltage remains with the limit for 7.2 kV.

Striker pins

Fuse links are generally equipped with a striker pin which can be used to indicate fuse link operation or to operate a trip mechanism where provided. The striker pin, which is actuated by a small pyrotechnic device, has characteristics as per IEC 282-1994. This requires a projection of 10mm minimum/16mm maximum from the end face of the fuse link and during this travel an energy output of 2 ± 1 joules must be produced. Type K fuse links are designed to produce energy towards the upper end of this band. A lockout feature is also incorporated with a minimum withstand force of 40 Newtons, which can be required to hold the trip bar of an associated switch in the locked out position. This prevents reclosure of the switch until the fuse links have been replaced.

In some applications a striker pin is not required: For example, fuse links mounted directly into transformer tanks and used as back-up protection only.

Available ranges

Maximum 3-phase Service voltage kV R.M.S.	Fuse type The letter X denotes a striker and is omitted in non striker version	Current rating in Amps	Breaking capacity* kA R.M.S. SYM.
12	KEBXO	5, 10, 16, 20, 25, 36, 40, 45, 50, 63, 80	20+#
12	KEMXO	5, 10, 16, 20, 25, 36, 40, 45, 50, 56, 63, 80, 90	20+
12	KEMXO	100, 120,	40

* Breaking capacity quoted are test values and apply at the maximum voltage rating.

*+ These ratings certified to more onerous requirements with actual test voltages at least equal to rated voltage.

Additional tests carried out for breaking capacity of 40kA at 7.2kV.



High Voltage HBC Fuselinks

Oil seals

An essential requirement for a fuse link used under oil is absolute integrity of the oil seal between end caps and body. For each end cap, the type K fuse link incorporates two rectangular section rings of high temperature and oil resistant rubber. This feature was first introduced over 40 years ago, and is well proven with many thousands of fuse links in service throughout the world. Fuse links of this type are subject to 100% testing of this feature during the course of manufacture. Type K fuse links meet the type test oil tightness requirements of BS 2692/IEC282

Capacitor Circuit Application

These fuse links are ideally suitable for HV capacitor protection also. The basic guidelines for normal circuit application are:

1. Where small capacitors are to be protected, the fuse current rating must be atleast twice the current rating of the capacitor.
2. The fuse link must withstand the capacitor inrush current during switching for a period during which the capacitor tries to settle down to carry normal current. This must be checked using the time/current characteristics of the fuse links selected as per 1 above.
3. For large installations where a lot of series/parallel connections are involved please refer to Works with complete data.

Operation in air

Most of these fuse link may be used in air, in which case the higher current ratings are subject to derating in respect of rated current.

Transformer circuit applications

The criteria for selection of fuse links for transformer circuit applications are covered in IEC 787 - 1983. the main requirements are shown in Fig.1 and are:

1. The H.V. fuse link must withstand inrush current. For practical purposes this means that the time/current characteristic must be to the right of the point given by 12 times transformer full load current and 0.1 seconds.
2. The in-unit H.V. fuse link current rating must be atleast as high as the permissible overload current of the transformer, assumed to be 150% in the table.

3. For complete co-ordination between the H.V. fuse link and secondary side protective devices the minimum pre-arcing time/current characteristic of the HV fuse and the total operating time/current characteristic of the secondary side protective device (referred to the primary side) should intersect at a higher value of current than the maximum fault current on the load side of the secondary protective device.

In order to ensure adequate protection of the transformer the pre-arcing current of the H.V. fuse link should be as low as possible in the 10 second region of the time/current characteristic.

Dimension in mm

Fuse Type	Ref BS2692/IEC282	L
KEBXO	F01	254
KEMXO	F02	359

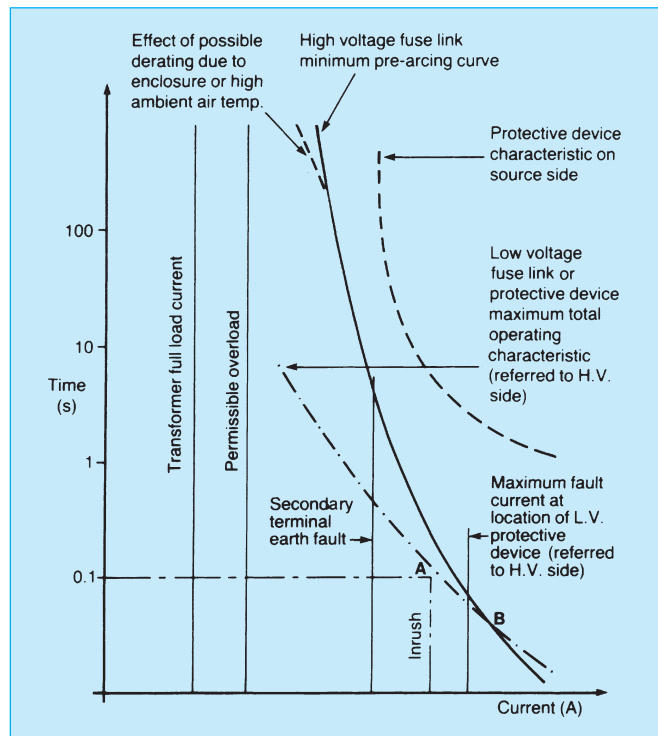
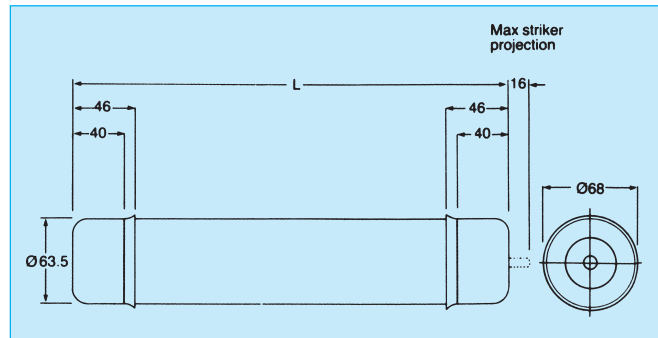



Minimum fuse ratings, recommended for 3-phase transformers

Transformer 3-phase Rating kVA	VOLTAGE RATING kV			
	6.6	10	11	12
25	10	10	5	5
30	10	10	10	10
40	10	10	10	10
63	16	10	10	10
75	20	16	16	10
100	20	16	16	16
125	25	20	20	20
150	36	20	20	20
200	36	25	25	25
225	40	36	25	25
300	50	36	36	36
315	50	36	36	36
400	63	45	40	40
450	80	45	45	40
500	80	50	50	45
600	100	63	56	50
630	100	63	56	56
750	100	80	80	63
800	120	80	80	80
1000	-	90	90	80
1250	-	120	100	100
1500	-	-	120	120



High Voltage HBC Fuselinks

Minimum breaking current table

List Number	Minimum breaking Current I ₃ A
KEBXO5	12.5
KEBXO10	27
KEBXO16	34
KEBXO20	48
KEBXO25	60
KEBXO36	95
KEBXO40	115
KEBXO45	130
KEBXO50	155
KEBXO63	195
KEBXO80	240
KEMXO5	12.5
KEMXO10	27
KEMXO16	34
KEMXO20	48
KEMXO25	60
KEMXO36	95
KEMXO40	105
KEMXO45	120
KEMXO50	145
KEMXO56	165
KEMXO63	170
KEMXO80	200
KEMXO90	240
KEMXO100	255
KEMXO120	300

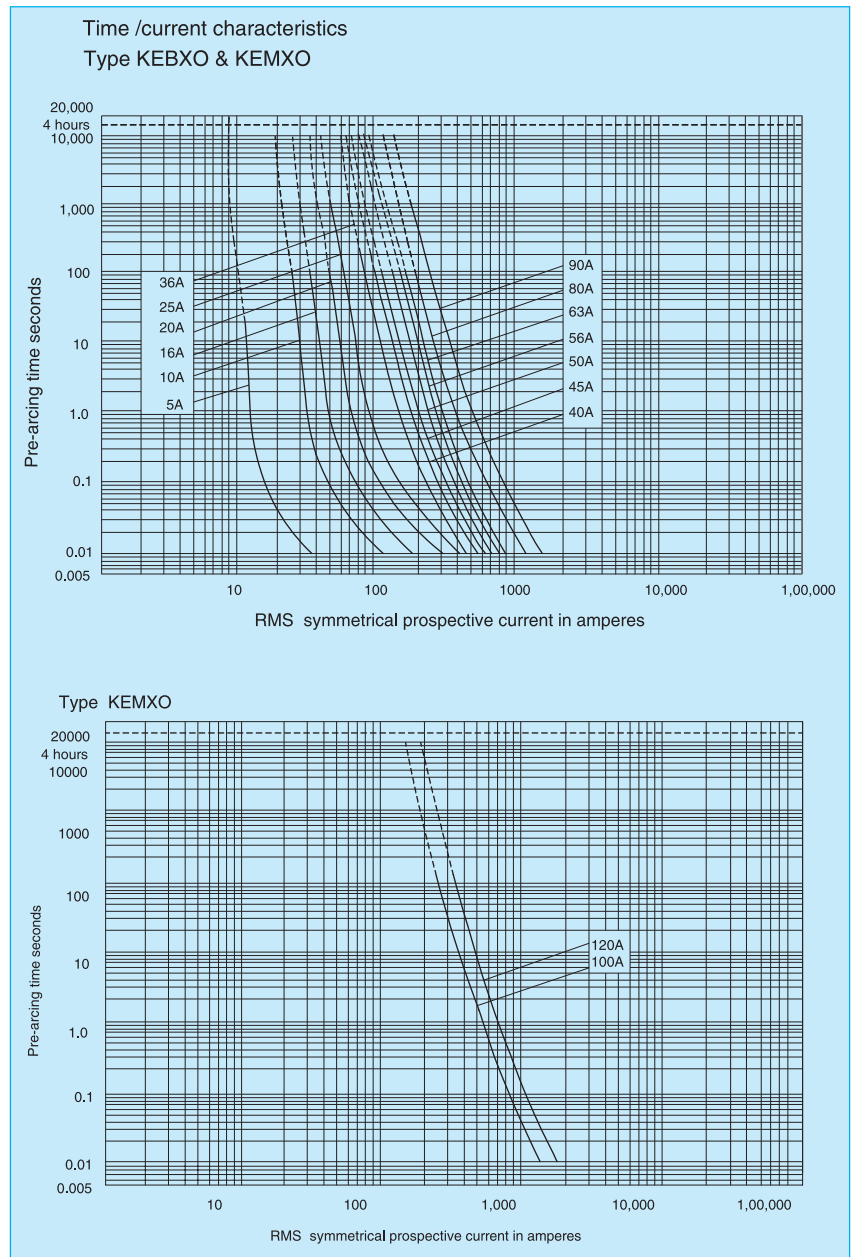



I²t Characteristics

List Number	Minimum Pre-arcing I ² t A ² S x 10 ³	Total I ² t A ² S x 10 ³
KEBX05	0.011	0.1
KEBX10	0.1	0.7
KEBX16	0.28	2.0
KEBX20	0.69	4.0
KEBX25	1.07	6.5
KEBX36	1.0	8.0
KEBX40	1.55	10.5
KEBX45	2.2	17.0
KEBX50	2.7	23.7
KEBX56	4.0	33.0
KEBX63	5.0	45.0
KEBX80	7.4	60.0
KEMX05	0.011	0.1
KEMX10	0.1	0.7
KEMX16	0.28	2.0
KEMX20	0.69	4.0
KEMX25	1.07	6.5
KEMX36	1.0	8.0
KEMX40	1.55	10.5
KEMX45	2.2	17.0
KEMX50	2.7	23.7
KEMX56	4.0	33.0
KEMX63	5.0	45.0
KEMX80	7.4	60.0
KEMX090	14.0	100.0
KEMX100	17.0	125.0
KEMX120	27.0	212.0

Cut-off Current Characteristics
type KEBXO/KEMXO

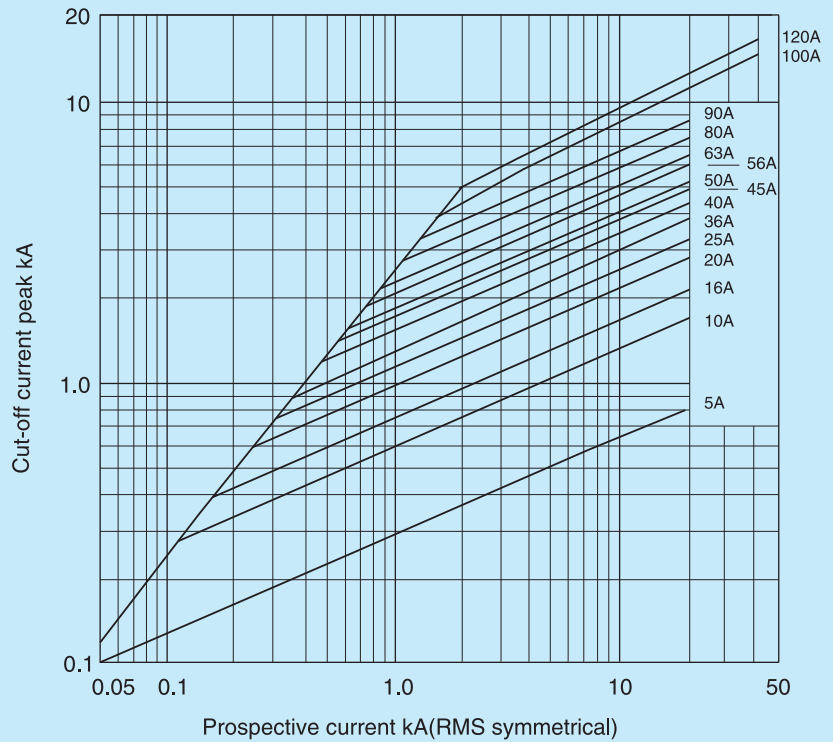



Type 'H' high voltage HBC fuse links

For 11kV Distribution/Capacitor Protection

GE PowerControls high voltage HBC fuselinks suitable for distribution circuits i.e., for protecting transformers, cables and capacitors - 5 Amps to 100 Amps - 11/12 kV systems.

AC Short Circuit Performance

The breaking capacity of type H2CAS/H3CAS is 36kA at 12 kV to IEC 282-1 : 1994.

Capacitor circuit applications:

Ideally suited for protecting HV capacitor circuits, designed to withstand capacitor in-rush currents.

For small capacitors, the fuse rating must be at least twice the current rating of capacitor. For large installations where a lot of series/parallel connections are involved, please refer to works with complete data.

Features :

- Excellent low over-current performance.
- Arc-voltage limits permits use in 7.2kV System.
- Striker pin operation for trip bar operation/indication.
- Transformer Circuit Applications

Time /Current Characteristics

Type H2CAS/H3CAS

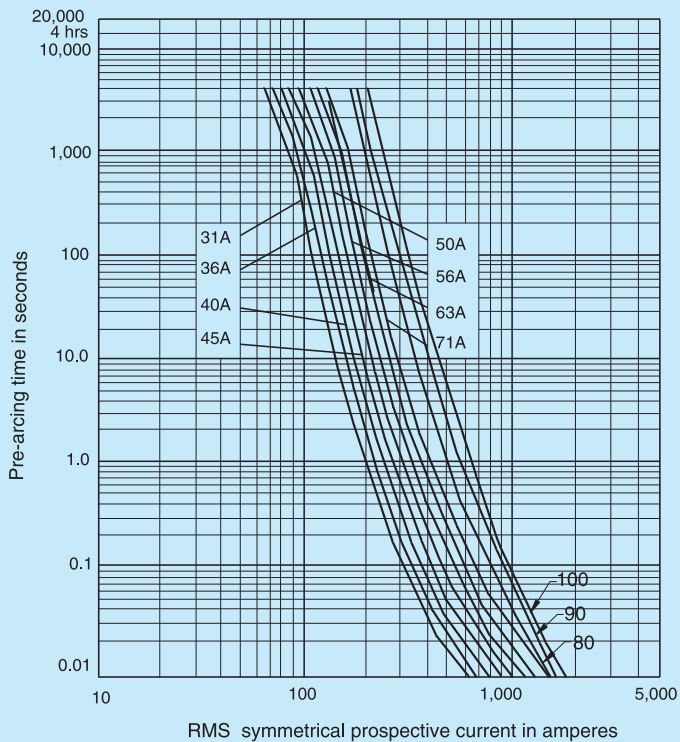
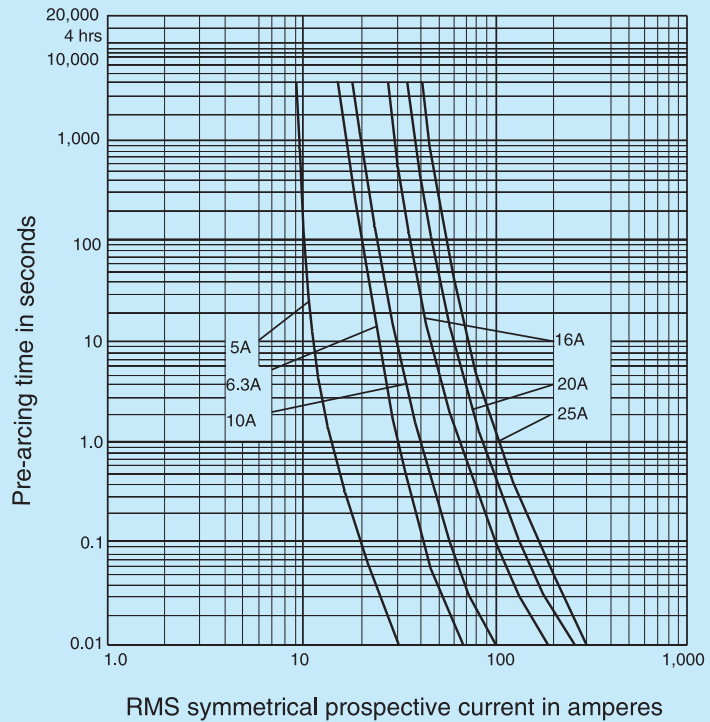



Cut-off current Characteristics Type H2CAS/H3CAS

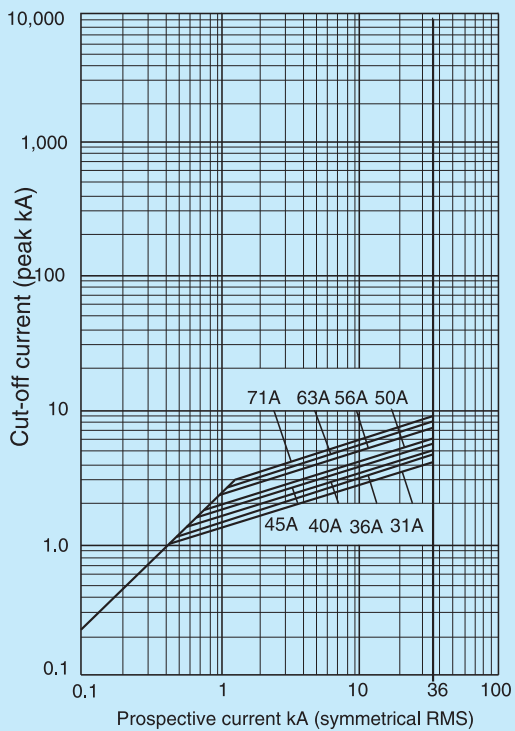
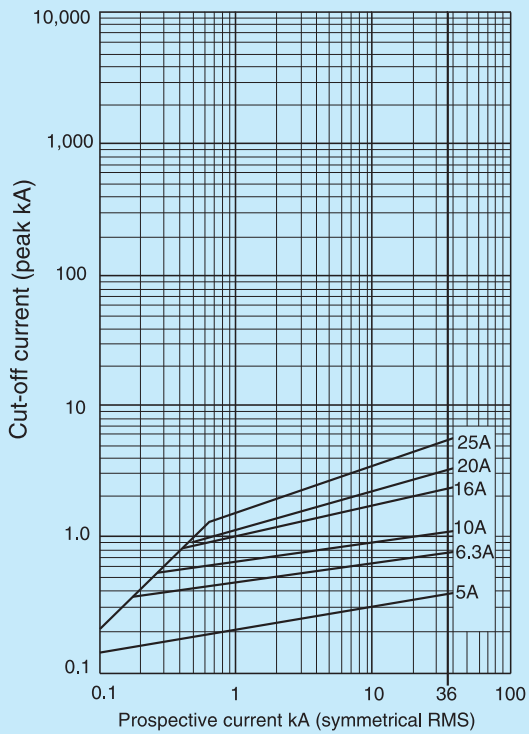

Cut-off Current Characteristics type H2CAS/H3CAS

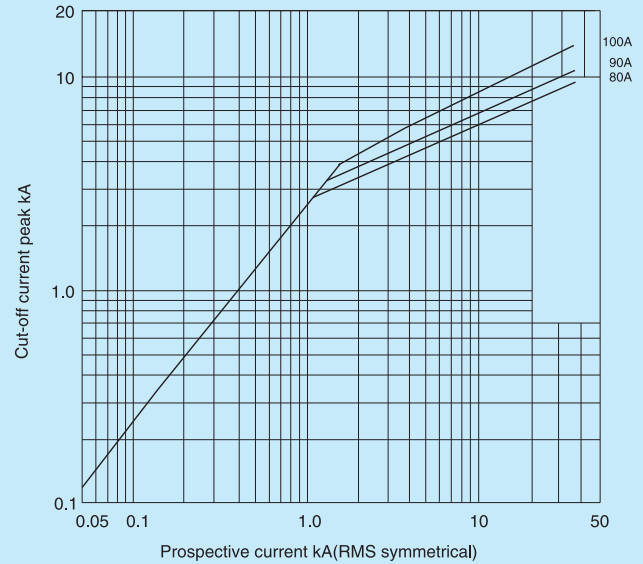

Dimensions of Fuse-link H2CAS for use in Air

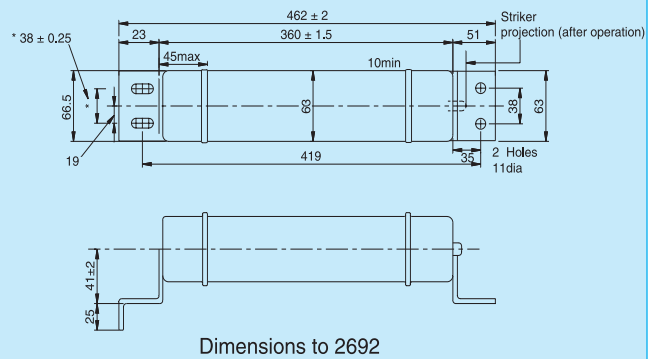

Dimensions of Fuse-link H3CAS for use in Air

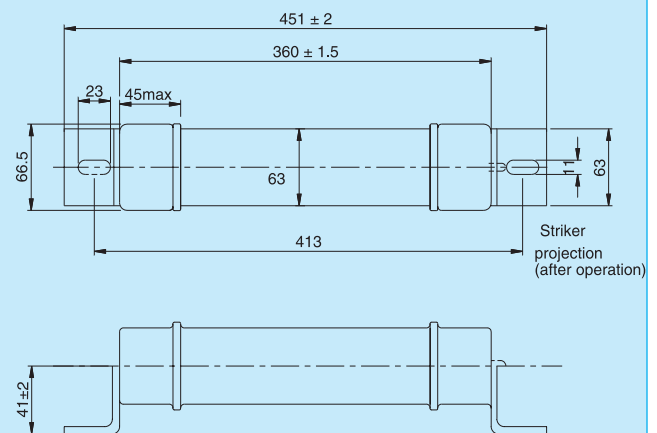



High Voltage HBC Fuselinks

Current Ratings

Fuse Ref	Current Rating (Amps)																
H2CAS	5	6.3	10	16	20	25	31	36	40	45	50	56	63	71	80	90	100
H3CAS	5	6.3	10	16	20	25	31	36	40	45	50	56	63	71	80	90	100

I²t Characteristics

Fuse Rating (A)	5	6.3	10	16	20	25	31	36	40	45	50	56	63	71	80	90	100
Min Pre-Arcing I ² t (A ² S)	10	250	400	550	900	1800	2000	3200	4500	5500	7000	8200	10000	10200	14000	17000	27000
Total op. I ² t (A ² S)	70	1400	2000	3000	5500	9500	6000	11000	15000	16000	20000	25000	30000	40000	100000	125000	212000

Minimum breaking current

Fuse Ref	Current Rating (Amps)																
H2CAS/H3CAS	5	6.3	10	16	20	25	31	36	40	45	50	56	63	71	80	90	100
Min. breaking Current I ₃	12.5	18	27	34	48	60	95	95	105	120	145	165	170	195	240	255	300

It should be stressed that use of a fuselink having too high a value of minimum breaking current, could under certain circumstances, result in disruptive failure of the fuselinks and consequent damage, arising out of fuselink clearing faults below the minimum breaking current.



Motor starting applications

High voltage fuselinks used in motor circuits must have the ability to withstand, without deterioration, the repeated surges associated with motor starting. Reliability in this respect is essential and must be provided without compromise to other essential parameters of performance and within the bounds of size and economy.

The ability to co-ordinate precisely with contactors and 'upstream' protective devices in the same system, together with adequate short circuit capacity are essential for safety. Fault energy limitation to minimise damage resulting from electrical faults is equally important.

The GE Power Controls range of 3.6kV and 7.2kV fuselinks meets these requirements and represent a significant advance in the design of high voltage fuselinks for motor starting applications. The range has the following advantages:

Higher current rating within single body dimensions.

"Proven ability to resist ageing under repeated starting conditions coupled with increased motor starting capability for given ratings.

"Lower values of current and energy let-through under maximum fault conditions.

Ability to withstand motor starting

Where fuselinks are used for motor circuit protection in conjunction with contactors, the current rating of the fuselink is usually of secondary consideration. The main criterion in the choice of rating is the ability of the fuselink to withstand repeated starting current surges for the run up time of the motor, without deterioration.

Fuselink selection chart gives recommended fuselink ratings for particular starting currents with various run-up times and frequency of starting.

AC short circuit performance

"BS 2692-1986, IEC 282-1-1994 for 45kA, 7.2kV

"BS 2692-1986, IEC 282-1-1994 for 40kA, 3.6kV

The values of cut-off current and I^2t let through are those obtained under the most severe short circuit conditions, specified in IEC 282-1. Arc voltages produced during operation are substantially below the maximum specified in both BS 2692 and IEC. 282-1.

Low overcurrent performance

The range has improved performance under low overcurrent conditions and extends considerably the safe operating zone of the fuselink.

Fuselinks should be selected so that the value of minimum breaking current is appropriate to the particular application concerned. Fuselinks guarantee protection against all fault currents ranging from the minimum breaking current to the maximum breaking capacity. The minimum breaking current for each rating is given in the table. It is recommended for a fuselink to be co-ordinated with an overcurrent protective device, an overload relay, with the minimum breaking current always lower than the intersection of the prospective time/current characteristics. It should be stressed that use of a fuselink having too high a value of minimum breaking current, could under certain circumstances, result in disruptive failure of the fuselinks and consequent damage, arising out of fuselink clearing faults below the minimum breaking current.

Characteristics

The time/current characteristics shown relate to mean pre-arcing times and are accurate to within a manufacturing tolerance of $\pm 10\%$ related to current.

Application Notes

These selection charts enable the minimum rating of fuselink to be determined for particular Motor Starting conditions and the following points must be considered in choosing the correct fuselink rating.

1. The number of starts per hour indicated in the charts are based on two of these starts being in immediate succession, the remainder being evenly spaced in the 1 hour period.

The charts indicate a rate of starting : For example 8 starts in 15 min. is represented as 32 starts per hour.

2. They enable the selection of the lowest rated fuselink to withstand the specified starting conditions. However, it is also necessary to ensure that the fuselink rating is not less than 1.33 times the normal full load current.

It is advisable to replace fuselinks in all the three phases when the fuselink in one or two phases of a three phase circuit has operated, unless it is definitely known that no over-current has passed through the unmelted fuselinks.

Method of Selection

- Select the chart covering the voltage rating and run-up time of the motor.
- Select starting current on the horizontal axis.
- Read off on vertical axis fuselink rating corresponding to intersection of starting current and required number of starts per hour line.



High Voltage HBC Fuselinks

Example : Motor with run-up time 6 secs.; 8 starts per hour.

F.L.C. 92A Starting current 552A.

- (a) Select Chart A.
- (b) Select 552A on horizontal axis.
- (c) Read off, on vertical axis, the fuselink rating corresponding to intersection of 552 on the 8 starts per hour line, which in this case is 125A rating.
- (d) This fuse rating is greater than 1.33 times 92Amp., motor full-load current, therefore the final fuselink selection will be 125A rating.

Min. Breaking Current

Type	Rating	Min. break I ₃ current
K81SVX	50A	200A
K81SVX	63A	350A
K81SVX	80A	350A
K81SVX	100A	250A
K81SVX	125A	450A
K81SVX	160A	500A
K81SVX	200A	760A
K81SVX	250A	650A
K81SRX	315A	760A
K81SRX	350A	950A
K81PEX	100A	315A
K81PEX	125A	370A
K81PEX	160A	370A
K81PEX	200A	590A
K81PEX	250A	710A
K81PEX	315A	710A
K81PEX	350A	710A
K81PRX	450A	1000A
K3PGX	5A	8A
K3PGX	10A	17A
K3PGX	16A	32A
K3PGX	20A	39A
K3PGX	25A	60A
K3PGX	32A	70A
K3PGX	40A	95A
K3PGX	50A	120A
K3PGX	63A	140A
K3PGX	80A	170A

RANGE

Voltage Rating	List No.	Rating (A)
3.6kV	K3PGX	5, 10, 16, 20, 25, 32, 40, 50, 63, 80
3.6kV	K81PEX K81PRX K82PFX	100, 160, 200, 250, 315, 350 450 630
7.2kV	K81SVX K81SRX K82SSX	50, 63, 80, 100, 125, 160, 200, 250 315, 350 400, 500, 630



Selection Charts 7.2kV

Types 'K81SVX' & 'K81SRX'

Chart A

Motors with run-up times not exceeding 6 seconds

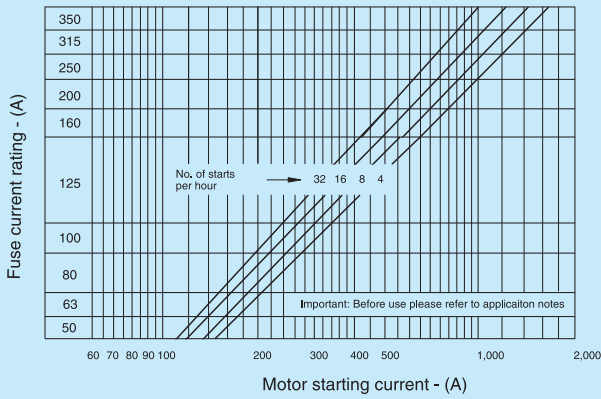

Chart B

Motors with run-up times not exceeding 15 seconds

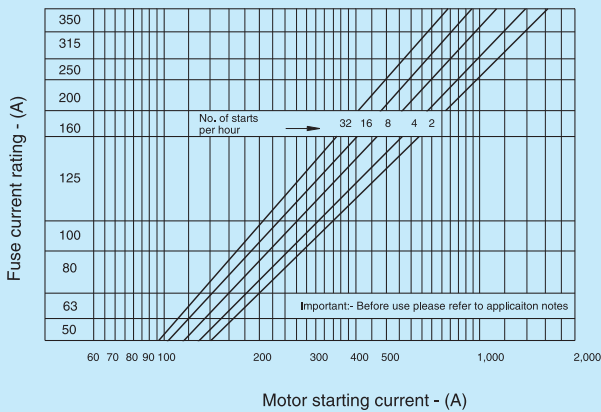
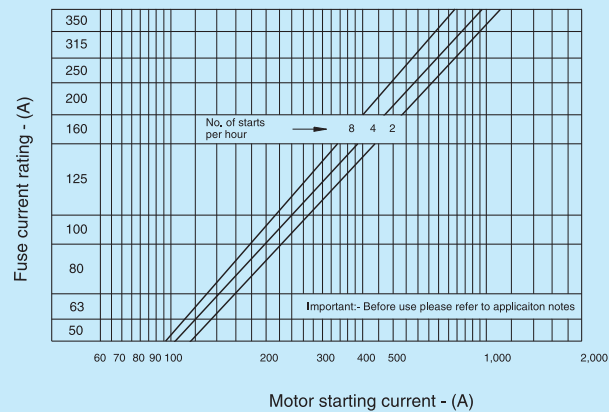

Chart C

Motors with run-up times not exceeding 60 seconds



Selection Charts 3.6kV

Types 'K3PGX'

Chart D

Motors with run-up times not exceeding 6 seconds

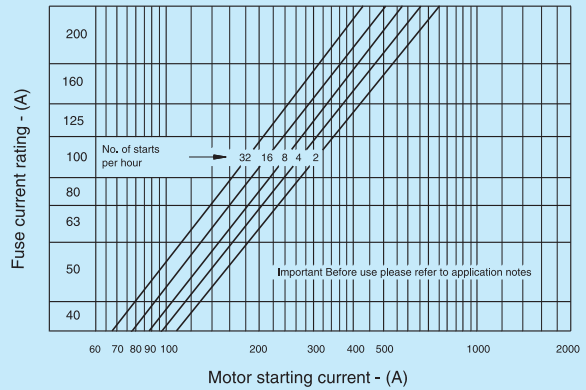

Chart E

Motors with run-up times not exceeding 15 seconds

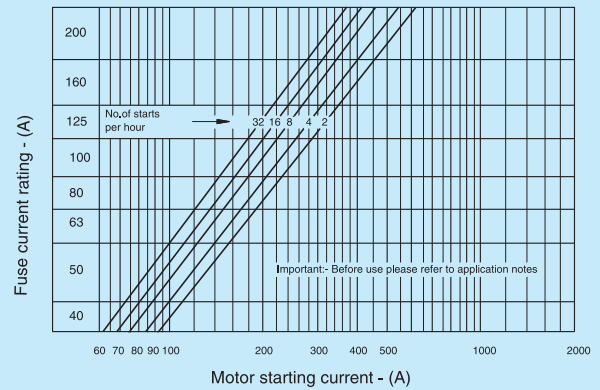
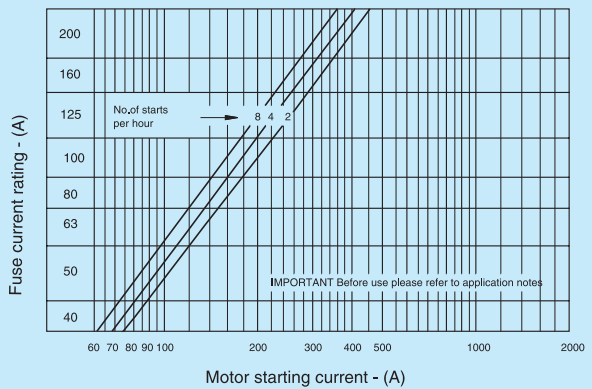

Chart F

Motors with run-up times not exceeding 60 seconds





Selection charts 3.6kV Types 'K81PEX' & 'K81PRX'

Chart G

Motors with run-up times
not exceeding
6 seconds

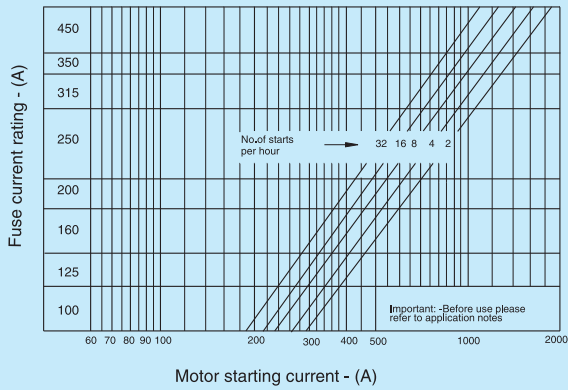

Chart H

Motors with run-up times
not exceeding
15 seconds

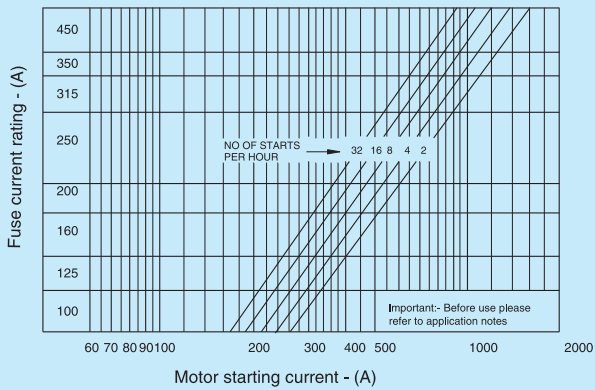
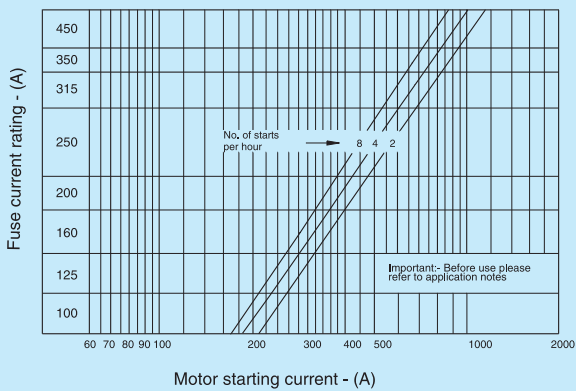

Chart I

Motors with run-up times
not exceeding
60 seconds





High Voltage HBC Fuselinks

I²t Characteristics

Fuselink Rating Amp	Pre-arcing I ² t A ² Sx10 ³	Total I ² t A ² Sx10 ³
5	0.011	0.22
10	0.1	2.0
16	0.38	7.5
20	0.68	13
25	0.94	20
32	1	30
40	1	30
50	3.2	60
63	4.5	90
80	7	150

Characteristic curve - Type K3PGX

Time/current characteristics

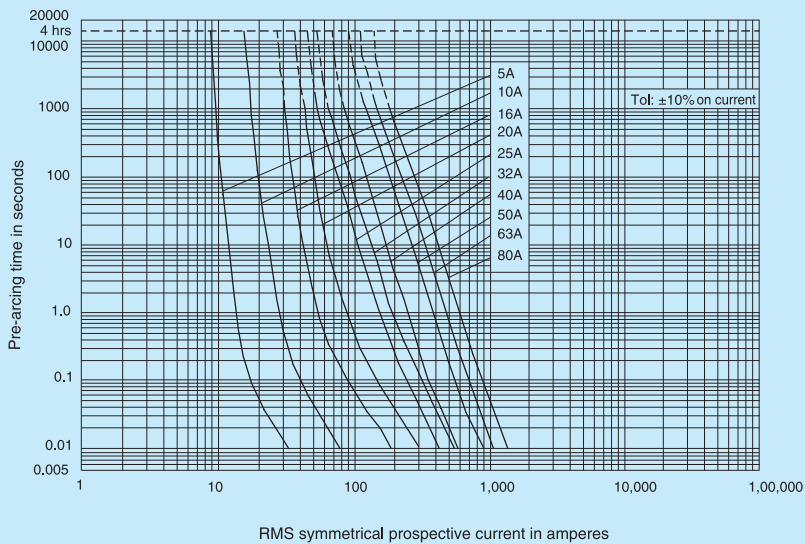

Cut-off current characteristics

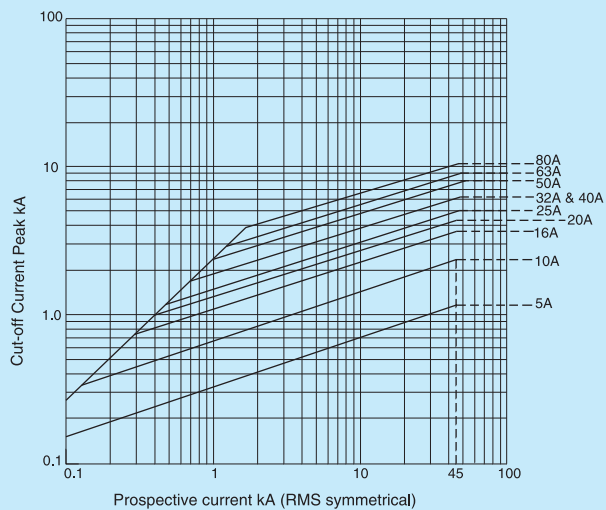



High Voltage HBC Fuselinks

I²t Characteristics

Fuselink Rating Amp	Pre-arcing I ² t A ² Sx10 ³	Total I ² t A ² Sx10 ³
100	23	270
160	59	570
200	92	770
250	235	1400
350	540	3100
450	540	6400
630	1220	6800

Characteristic curves-Types K81PEX, K81PRX AND K82PFX

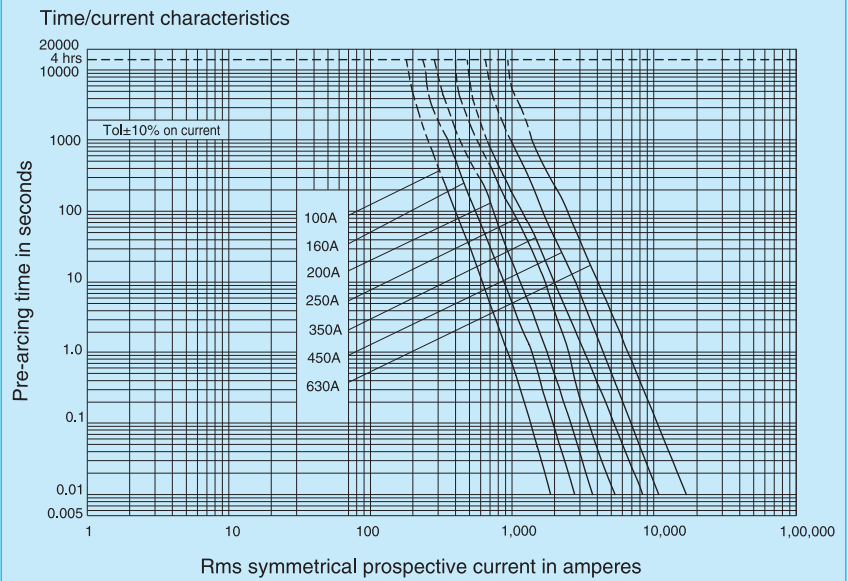

Cut-off current characteristics

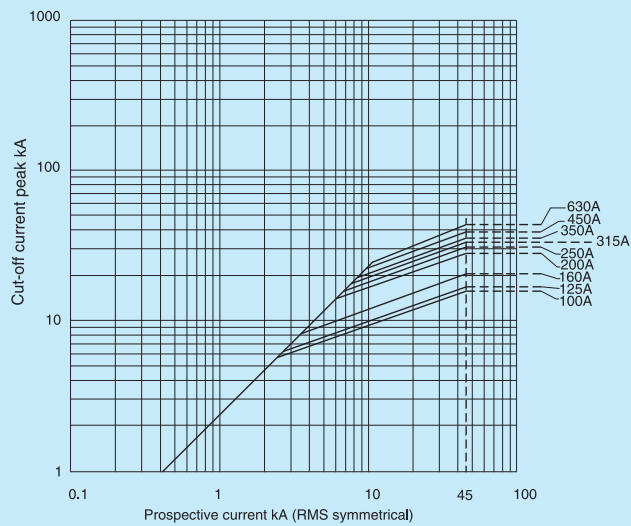



High Voltage HBC Fuselinks

I²t Characteristics

Fuselink Rating Amp	Pre-arcing I ² t A ² Sx10 ³	Total I ² t A ² Sx10 ³
50	2.8	32
63	4.3	49
80	9.7	110
100	17.2	195
125	33.9	315
160	60.1	500
200	136	990
250	241	1600
315	541	3100
350	845	4500
400	960	6400
500	2160	12400
630	3380	18000

Characteristics curves-Types K81SVX,K81SRX,K82SSX.

Time/Current Characteristics

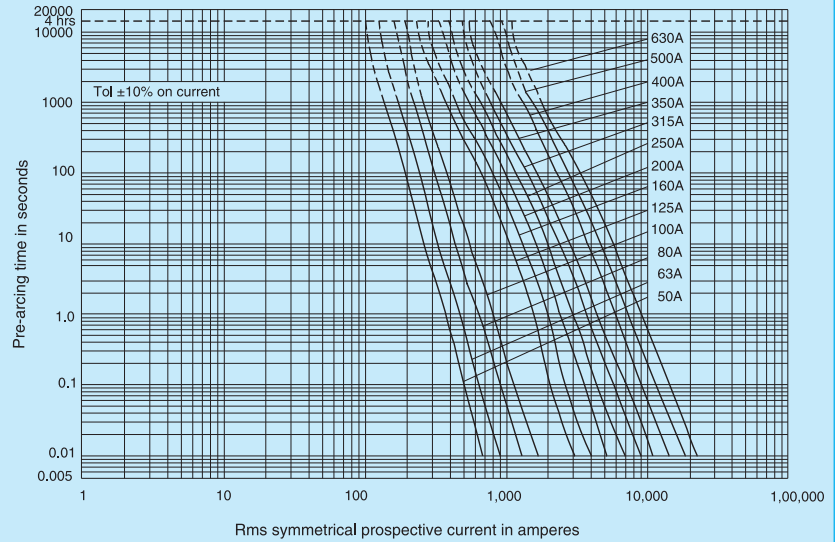

Cut-off Current Characteristics

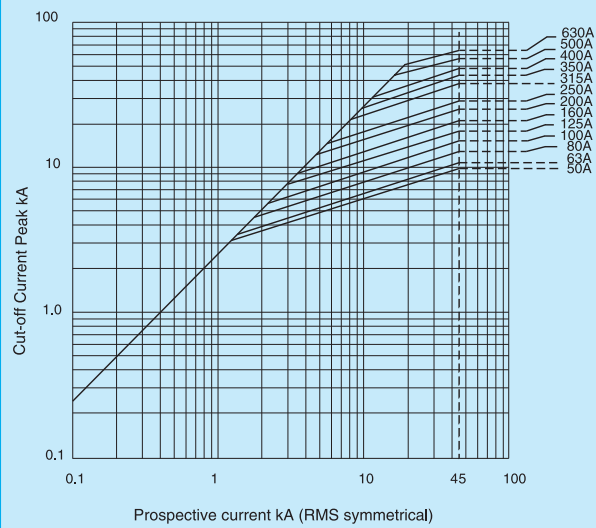



High Voltage HBC Fuselinks

LIST NUMBERS AND DIMENSIONS

(All dimension in mm)

Type K3PGX

Striker projection (After operation)

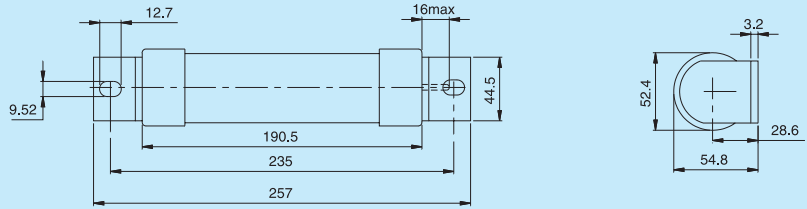

Types K81PEX AND K81PRX

Striker projection (After operation)

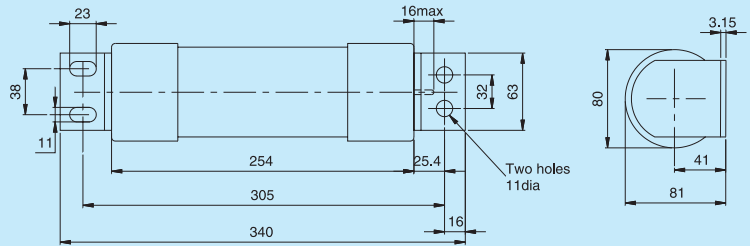

Type K82PFX

Striker projection (After operation)

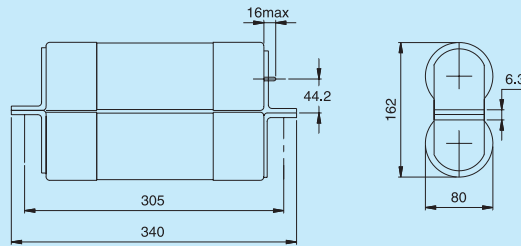

TYPE K81SVX/K81SRX/K82SSX

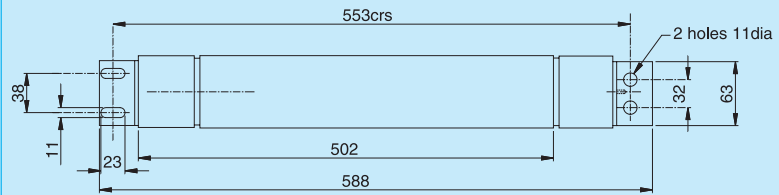

TYPE K81SVX/K81SRX

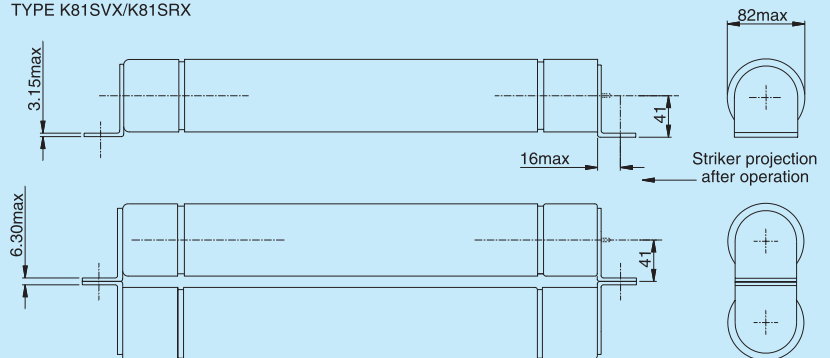



Voltage Tranformer fuse links

Suitable for use in Air or Oil

Current and voltage ratings

Fuse List Number	Current Rating Amp	Voltage Rating kV	Maximum System Voltage kV
VTF 6.6/3	3	6.6/3.3	7.2
VTF 11/3	3	11	12

A.C. short-circuit performance

The range has been tested to IEC 282 as follows

VTF 6.6	43.9 kA	3.3 kV
	30.7 kA	6.6 kV
VTF 11	52.5 kA	11 kV

Characteristics

The time current characteristics shown relate to mean pre-arcing times and are accurate to within $\pm 10\%$ related to current.

These fuses are fitted with ferrule type end connections as standards, but are also available with stud type (5 x VTF 11- for 11 kV) end connections as shown..

Dimensions in mm

Type	A	B	C	D	E
VTF 6.6/3	143	31.8	25.4	7.3	7.9
VTF 11/3	194	31.8	25.4	7.3	7.9

Time/Current characteristics

