

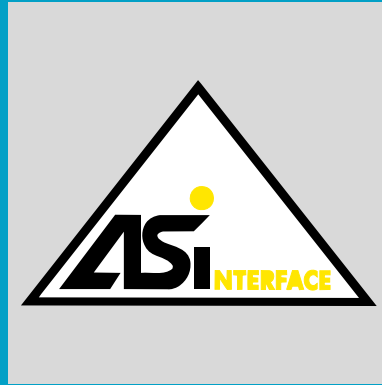

GE Power Controls

New AS-i
Actuator Sensor Interface



AS-i Fieldbus System





Actuator Sensor Interface



Single master



I/O flat module



I/O standard module



I/O slim module



Power supply

Table of contents

2	AS-i fieldbus system
2	Actuator Sensor Interface
3	Main advantages / Main features
4	AS-interface cables / AS-interface message
5	Masters and gateways / Power supplies
6	AS-i components
6	Single Master
7	Double Master
8	Master PC Board
9	Master PLC Board (GE Fanuc VersaMax™)
10	Profibus DP Gateway IP20
11	Profibus DP Gateway IP67
12	DeviceNet Gateway
13	Standard modules
18	Flat modules
23	Slim modules
29	Standard bases / Mounting plate
30	Power supply 2.4A & 7A
31	Repeater
32	Accessories
33	Cable
34	Address programming device
35	Control software
36	Numerical index

Actuator Sensor Interface

AS-i (Actuator Sensor interface) is a low electromechanical connection system designed to operate over a two wire cable carrying **data** and **power** over a distance of up to 100 meters or more if repeaters are used.

This fieldbus system has been designed to provide cost effective, convenient and simple networking solution of sensors and actuators with connection to a control system. The bus is specially suitable for lower level of plant automation where simple (binary) field devices need to interoperate in a stand alone local area automation network controlled by a PC or PLC.

AS-interface replaces the cable tree connections on the lower field level as shown in the figures on the right which illustrate the difference between AS-interface and conventional wiring.

The AS-interface technology replaces the work intensive wiring, with an estimated cost reduction during installation of 15% to 40% compared with the traditional cabling.

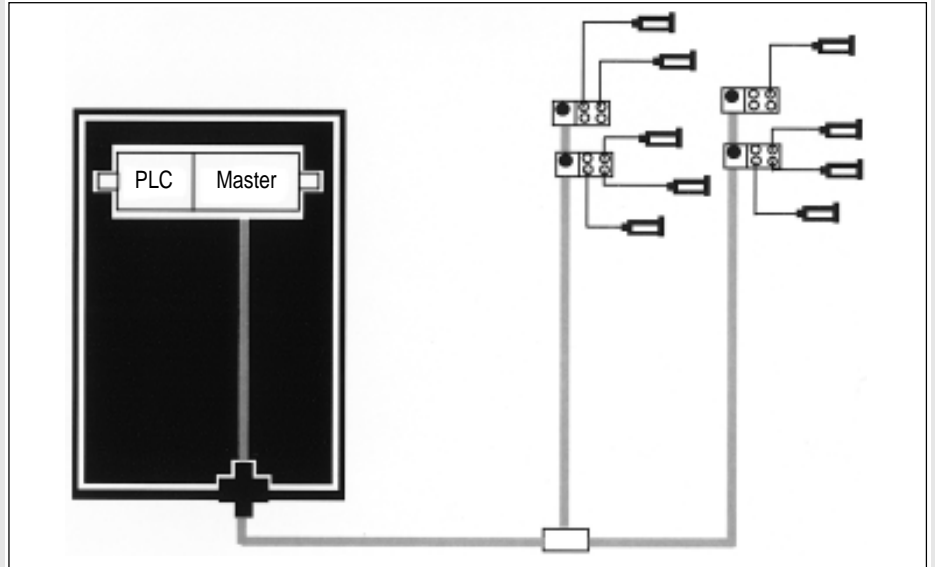

Actuator Sensor interface

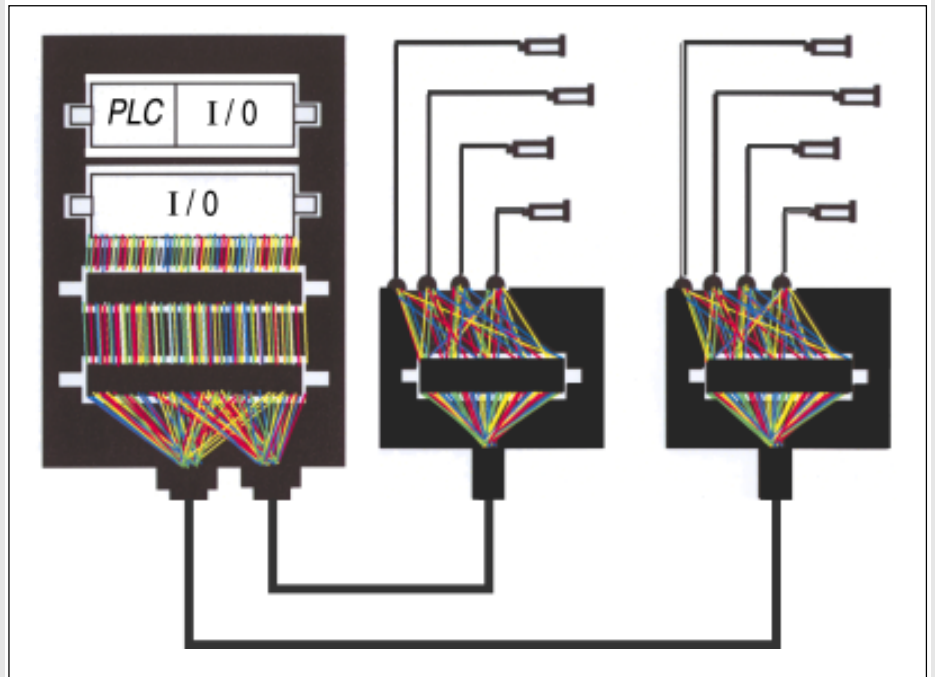

Conventional wiring

Main advantages

- **Fast:** Real time requirements of most control systems. (max. response delay 5 ms)
- **Simple:** Data and power are transmitted together. Data transmission is pre-defined and the software is friendly to use.
- **Cost effective:** The use of a two wire cable for both power and data reduces drastically the number of connection points; reducing in consequence labour cost.
- **Reliable:** High degree of data integrity, non-stop monitoring of the network and excellence diagnostic.

Main features

- Topology: free topology (line, star, tree...)
- AS-i flat cable: 2 wire unshielded cable 2 x 1.5 mm² (16 AWG)
- Length of cable: 100 meters (up to 300 meters if repeaters used)
- Number of slaves (I/O): 31 max.
- Number of participants: up to 4 sensors and 4 actuators per slave (248 binary participants)
- Addresses: each slave gets a definite address, setting of the address by the master or by a handheld programming tool.
- Transmission rate: 4 bits per slave and message
- Cycle time with 31 slaves: 5 ms
- Data transmission: APM with sin² signal
- Bit encoding: Manchester II
- Transfer rate: approx. 167 kbits/s
- Analogue data: 16 bit word transmitted in 6 cycles

AS-i structure

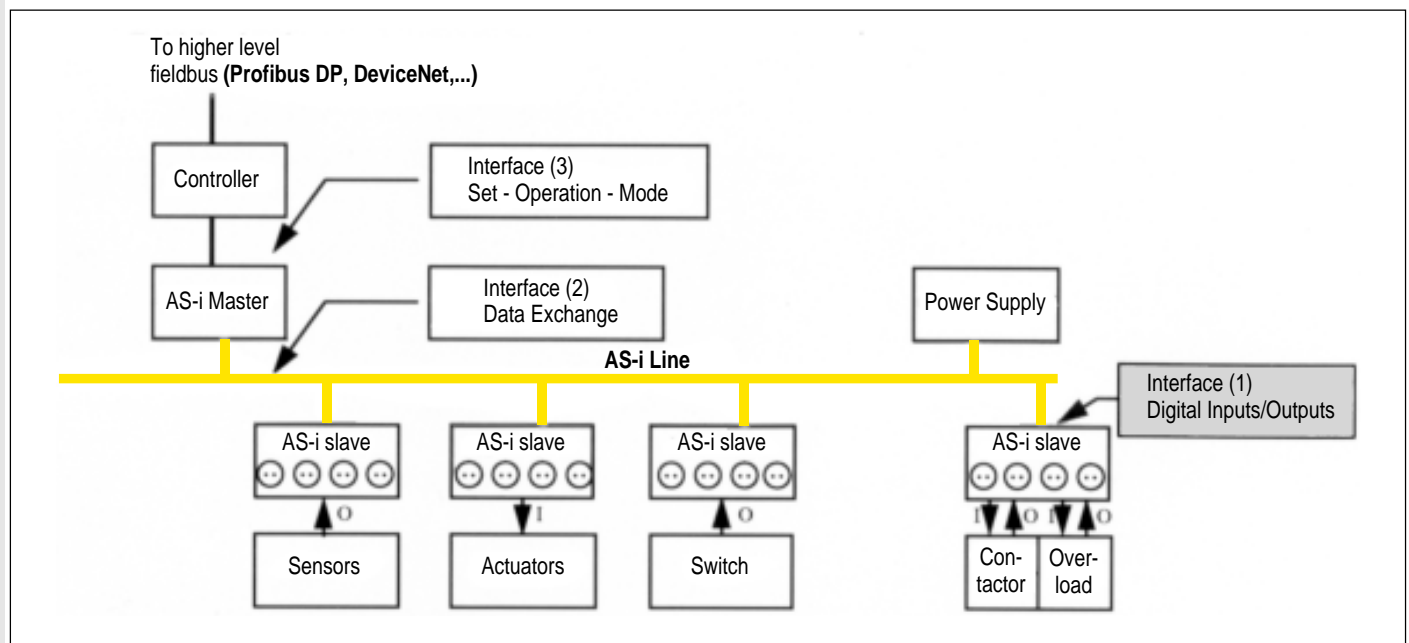

- (1) **Sensor-actuator side:** The slave establishes the connection to the sensor or actuator.
- (2) **Transmission system:** The AS-interface standard (IEC-D) entirely and precisely describes this interface. All conditions for data and power transmission are defined, as well as all functions for the transmission of data and parameters, addressing and identification or status check of the slaves.
- (3) **Controller side:** the master establishes connection to the controller which is a PLC, PC or coupler to a high-level fieldbus system. The master controls the data exchange with the slaves via the transmission system and carries out the necessary management function.

AS-interface options

- Integrated into actuators - sensors - starters
- Separate modules providing interface for **up to 4 conventional actuators / sensors**

AS-interface cables

AS-interface provides two different cable solutions:

- Two round cables may be used with a minimum cross section of 1.5 mm² (16A WG).
- AS-i flat cable ("yellow" or "black" according circumstances).

Main advantages to use the AS-i cables are:

- Transmission of **data** and **power** (supply voltage approx. 30V DC) through the same cable.
- Reverse polarity protection by mechanical coding.
- Terminating resistors are not required.
- Supporting any topology, a branch can be placed at any location along the network.
- The total length of the cable can not exceed 100 meters (possibility to be expanded using repeaters).
- The power to the AS-i network is transmitted through the cable and it is provided by the AS-i power supply. This may be mounted at any point along the network.

Black cable: Normally used when an additional power source of 24V dc is required. The black cable is placed parallel to the yellow flat cable in the IP67 standard and flat modules. GE Power Controls has a special base type BLCTBYB which support the 4 outputs and 2 inputs/2 outputs standard modules. This base has been specially designed to support parallel cabling method.

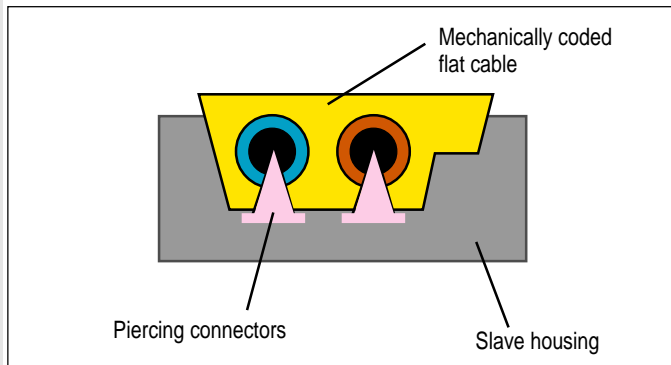

The piercing technology (penetration technique) makes the contact between the AS-i cable and the slave without cutting and stripping the cable in an easy and efficient method. In case that a slave should be removed, the points where shaped contact enters in the cable close guarantying no water penetration.

Topologies

Free choice of network structure according to application convenience.

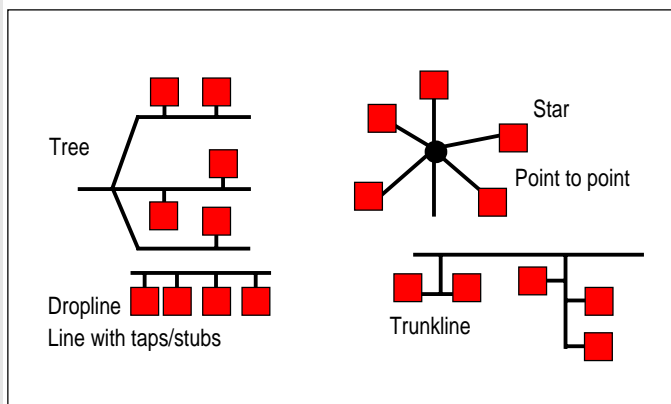

AS-interface message

An AS-i message consists of a master request (14 bits), a master pause (between 3 and 10 bits), a slave response (7 bits) and a slave pause (1 or 2 bits).

Master request														Master pause		Slave response					Slave pause	
0	SB	A4	A3	A2	A1	A0	I4	I3	I2	I1	I0	PB	1	0	I3	I2	I1	I0	FB	1		
ST														EB		ST					EB	

ST = start bit
 SB = control bit
 A4 ... A0 = address of slave
 I4 ... I0 = information part
 PB = parity bit
 EB = end bit

Structure of an AS-i message

A master request consists of

ST	start bit	Marks the beginning of a master request = 0 : valid start bit = 1 : not allowed
SB	control bit	Marks data/parameter/address or command calls = 0 : data/parameter/address call = 1 : command call
A0 ... A4	address	Address of the called slave (5 bit)
I0 ... I4	information	Depending on the type of request the 5 bits contain the information to be transferred. Details are given in conjunction with every message
PB	parity bit	Parity bit, sum of all "1" in the master request without end bit must be even
EB	end bit	Marks the end of the master request = 0 : not allowed = 1 : valid end bit

The slave response consists of

ST	start bit	Marks the beginning of a slave response = 0 : valid start bit = 1 : not allowed
I0 ... I3	information	Information bits
PB	parity bit	Parity bit, the sum of all "1" in a slave response without end bit must be even
EB	end bit	Marks the end of the slave response = 0 : not allowed = 1 : valid end bit



Masters and gateways

The AS-i masters/gateways are the core of all the bus system. Both masters and gateways connect the network to upper level controllers as PLC, PC or higher level bus systems as Profibus DP or DeviceNet (both available in GE AS-i product basket). Masters and gateways organise the complete data transfer, cyclically polling all participants of the network.

In case of the GE Power Controls "stand alone" masters/gateways the connection to an upper level system can be done with a serial interface RS485, direct connection to a PC or PLC or a serial field bus system. The RS485 interface (industrial interface) allows to use long cables lengths and to link a host with up to 31 slaves. One important feature of all the GE masters/gateways is that all incorporate a micro PLC to execute the control program locally, reducing the processing time in the application. Conveniently the program can be uploaded, downloaded, started or stopped.

All stand alone masters/gateways offer a 16K program storage, 8K RAM, 1024 timers and 1024 counters. More information about the program software see page 35.

Stand alone double masters are also available in one device in case that two AS-i networks should operate in parallel.

GE Power Controls offers gateways to two upper level field buses: Profibus DP (IP20 to be mounted in an enclosure and IP67 to be mounted on the field) and DeviceNet (only IP20).

AS-i master for a GE Fanuc VersaMax™ PLC will be available first quarter 2000. (For more information about this PLC, refer to GE Fanuc Automation VersaMax™ I/O and Control catalogue)

Slaves (I/O modules)

The main function of the AS-i slaves is to connect the sensors/actuators to the AS-i network, to supply sensors/actuators with power and to carry out the communications with the master.

GE Power Controls offers three different ranges of I/O modules to meet the special needs of each application.

Slim modules (IP20)

The slim modules are used inside enclosures for control purposes where the minimum amount of space requires slim modules. Available in 22.5 mm width (4 inputs and 4 electronic outputs) and 45 mm width (4 inputs + 4 electronic outputs and 4 inputs + 4 relay outputs).



Standard modules (IP67)

Standard modules support both flat cable: yellow and black, connecting it via piercing technique.

Standard M12 connectors are used to connect sensors and actuators.

Different I/O configurations are available to provide a solution to all kind of applications.

I/O standard modules support two different coupling modules according power needs.

I/O standard modules	Coupling modules
4 inputs	2 yellow cables
4 electronic output	yellow + black cables
4 relay outputs	2 yellow cables
2 input + 2 electronic output	yellow + black cables
2 input + 2 relay output	2 yellow cables



Flat modules (IP67)

Only 29 mm high, ideal for limited space applications.

Standard M12 connectors are used to connect sensors and actuators.

Five different I/O configurations using the same coupling modules.

I/O flat modules	Coupling modules
4 input + 4 electronic output	yellow + black cables
8 input	yellow + black cables
4 input	yellow + black cables
4 electronic output	yellow + black cables
2 input + 2 electronic output	yellow + black cables



Power supplies

The power supplies can be connected at any point of the AS-interface network, but it is recommended to allocate them where the current consumption is relatively high.

GE Power Controls offers two different power supplies: 2.4A (suitable for yellow cable) and 7A (suitable for black cable). The specific current of the power supply must be greater than the sum of the I/O devices and the input currents from the field devices.

The following pages give a technical description of the GE Power Controls AS-interface product basket, including the program AS-interface software and all accessories which facilitate the use of this bus system.

Single Master

- Stand alone master with integrated PLC functionality
- Space saving design, ideal for use in an enclosure
- Advanced AS-i diagnostics
- RS485 serial interface
- Two digit LCD displaying slaves addresses and error messages
- Each master includes the standard software kit (cat. no. SSK)

Technical data

Operating current
Operating voltage
Baudrates
AS-i-cycle time
Serial interface
Insulation voltage
EMC directions
Protection degree
Shock resistance
Vibration resistance
Dimensions (L x W x H)
Weight
Operating temperature
Storage temperature
Mounting
Integrated PLC description
programm memory
data memory
remanent data memory in
cycle time
flags/registers
number of counters/timers
I/O up to 248 through
programming device
programming platform
programming tools

Displays

power	green LED
ser active	green LED
config. error	red LED
U ASI	green LED
ASI active	green LED
prg enable	green LED
prj mode	yellow LED
LCD	
push-buttons	



Cat. nr.	Code
BLCCS2T	108239
Master power supply A, 200 mA	
30V dc	
automatic recognition (1200, 2400, 4800, 9600, 19200, 38400 or 57600 baud)	
150 μ s* (number of slaves + 1)	
RS485	
\geq 500V	
EN 50082, EN 50081	
IP40 (housing), IP20 (terminals)	
15 g / 11 ms	
up to 55 Hz / 0.5 mm amplitude	
75 x 100 x 110 mm (DIN rail mounting)	
420 g	
0°C up to + 55°C	
- 25°C up to + 85°C	
DIN rail (EN 50022) / screws	
(EEPROM) 16kB	
(bit/byte flags) 8 kB	
EEPROM	
(1kbit/1000 word instruction) 1,8 ms/2 ms.	
8 kB	
1024 each	
AS-interface slaves	
PC	
Windows 3.1, Windows 95 up to 98	
standard software kit (SSK)	
registered software tool (BLCSS)	

Status

Power ON
Serial interface communication active
Configuration error
Correct AS-i voltage
AS-i normal operation active
Automatic addressing enable
Master is in configuration mode
Slave addresses and error messages
2 (mode / set)

Connection

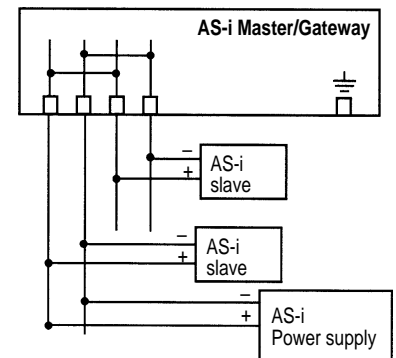

RS485 serial interface

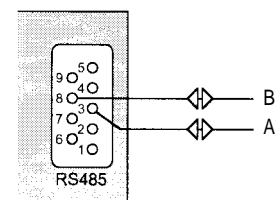

Accessories

Cat. nr.	Description
SSK	Standard software kit (free demo)
BLCSS	Registered software tool
INSMANBLCC	AS-i Masters user's manual

Double Master

- Stand alone master with integrated PLC functionality
- Space saving design, ideal for use in an enclosure
- Advanced AS-i diagnostics
- RS485 serial interface
- Two digit LCD displaying slaves addresses and error messages
- Each master includes the standard software kit (cat. no. SSK)

Technical data

Operating current
Operating voltage
Baudrates
AS-i-cycle time
Serial interface
Insulation voltage
EMC directions
Protection degree
Shock resistance
Vibration resistance
Dimensions (L x W x H)
Weight
Operating temperature
Storage temperature
Mounting
Integrated PLC description
programm memory
data memory
remanent data memory in
cycle time
flags/registers
number of counters/timers
I/O up to 248 through
programming device
programming platform
programming tools

Displays

AS-i 1 / AS-i 2	green LED
power	green LED
ser active	green LED
config. error	red LED
U ASI	green LED
prg enable	green LED
prj mode	yellow LED
LCD	
push-buttons	



Cat. nr.	Code
BLCCD2T	108240
Master power supply A, 200 mA from AS-i1 and 70 mA from AS-i2	
30V dc	
automatic recognition (1200, 2400, 4800, 9600 19200, 38400 or 57600 baud)	
150 μs* (number of slaves + 1)	
RS485	
≥ 500V	
EN 50082, EN 50081	
IP40 (housing), IP20 (terminals)	
15 g / 11 ms	
up to 55 Hz / 0.5 mm amplitude	
75 x 100 x 110 mm (DIN rail mounting)	
420 g	
0°C up to + 55°C	
- 25°C up to + 85°C	
DIN rail (EN 50022) / screws	
(EEPROM) 16kB	
(bit/byte flags) 8 kB	
EEPROM	
(1kbit/1000 word instruction) 1.8 ms/2 ms.	
8 kB	
1024 each	
AS-interface slaves	
PC	
Windows 3.1, Windows 95 up to 98	
standard software kit (SSK)	
registered software tool (BLCSS)	

Status

AS-i network 1 / AS-i network 2
Power ON
Serial interface communication active
Configuration error
Correct AS-i voltage
Automatic addressing enable
Master is in configuration mode
Slave addresses and error messages
2 (mode / set)

Connection

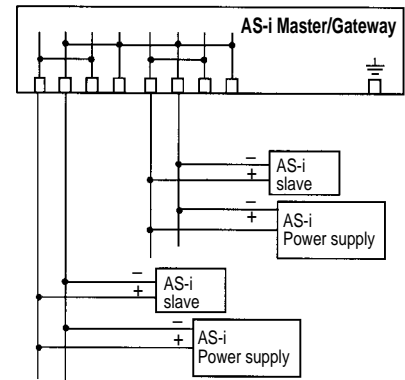

RS485 serial interface

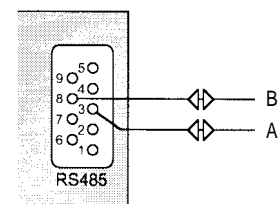

Accessories

Cat. nr.	Description
SSK	Standard software kit (free demo)
BLCSS	Registered software tool
INSMANBLCC	AS-i Masters user's manual

Master PC Board

AS-i PC board realises the functionality of a complete AS-i master on a short PC-board. In addition an implemented AS-i control unit performs as a PLC and an additional watchdog watches breakdowns on your PC system. If used without the AS-i control unit the board will work as a pure AS-i master. While the AS-i PC board controls the AS-i network, the full resources of the computer can be used for virtualisation or other applications. For normal operation there is no need for an interrupt, but the AS-i PC card is capable to generate interrupts leaded by events. Only 3 bytes of the I/O area are used.

Technical data	Cat. nr.	Code
Type	BLCCPBT	108241
Interface	Short AT-board	
Operation current	8-bit AS-interface, galvanical separation from AS-i network	
Operating voltage	200 mA from PC power supply, 70 mA from AS-i network	
Baudrates	5V dc and AS-i 30V dc	
AS-i cycle time	automatic recognition (1200, 2400, 4800, 9600, 19200, 38400 or 57600 baud)	
Insulation voltage	150 μ s* (number of slaves + 1)	
EMC	> 500V	
Operating temperature	EN 50082, EN 50081	
Storage temperature	0°C up to + 55°C	
PC requirements	- 25°C up to + 70°C	
	IBM compatible PC 80286 or higher	

The watchdog can set the master into the offline phase, if it is not triggered by a PC program. Advanced AS-i diagnostics to detect occasional occuring configuration errors and to judge the quality of the AS-i interface communication are implemented. AS-i PC board uses a DPRAM interface for data exchange. This fact provides an easy embedding in any PC operating system. I/O data is readable all time. Up to 8 boards can be used simultaneously in one PC and can share one interrupt. The board serves the requirements of industrial use.



Connection

Possible connection topologies

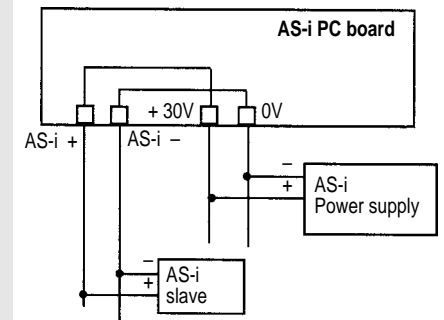
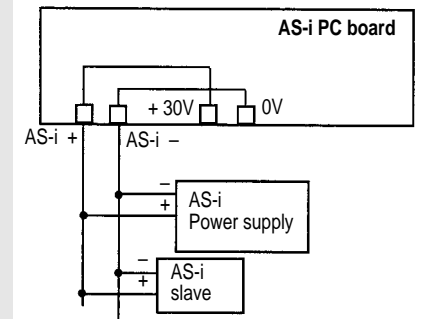

Accessories

Cat. nr.	Description
SSK	Standard software kit (free demo)
BLCSS	Registered software tool
INSMANPC	AS-i PC Board user's manual



Master PLC Board GE Fanuc VersaMax™

- AS-interface master module for the VersaMax™ PLC (GE Fanuc)
- Can be used both with VersaMax™ PLC and VersaMax I/O station
- 4 status LEDs and 2 numeric displays provide fast detection of failures and diagnosis

Technical data

Length of % I	
% Q	
% AI	
% AQ	
Address range of slaves	
Maximum number of slaves	
Maximum data per slave	
Isolation: Network to frame ground	
Indicators LED	
Current drawn from backplane	
Network data rate	
CPU sweep time impact	
Network topology	
Maximum bus length, including all cable section	
Medium	
Maximum bus cycle time	
Messaging	
Termination required	

Displays

OK	green LED
PROT	green LED
FLT	red LED
APF	green LED
2x 7-segment displays	
push-buttons	



Cat. nr.

IC200BEM104

160 bit (20 byte)
160 bit (20 byte)
0
0
1-31
31
4 input bits and 4 output bits
50 VAC continuous, 500 VAC for 1 minute
OK, PROT, FLT, APF, 2x 7-segment displays
350 mA max at 5 Volt +/- 3%
166-2/3 Kbits/second
50 μsec
Tree structure
100 meters without repeaters
300 meters with 2 repeaters
Unshielded 2-wire cable for data and power
5 ms with 31 slaves
Cyclic polling
none

Status

Slave addresses and error messages
1 (mode / store)

Accessories

Cat. nr.	Description
IC200CHJ006B	Communication carrier

Profibus DP Gateway IP20

- Connection to Profibus DP
- Configuration without Profibus communication
- Integrated PLC functionality
- Error diagnostics via LEDs and LCD

Technical data

Operating current
Operating voltage
Baudrates
AS-i cycle time
Profibus interface
Profibus functions
Insulation voltage
EMC directions
Protection degree
Dimensions (L x W x H)
Weight
Operating temperature
Storage temperature
Integrated PLC description
programm memory
data memory (bit/byte flags)
remanent data memory in
cycle time (1kbit/1000 word instruction)
flags/registers
number of counters/timers
I/O up to 248 through
programming device
programming platform
programming tools

Displays

power	green LED
Bus active	green LED
config. error	red LED
U ASI	green LED
ASI active	green LED
prg enable	green LED
prj mode	yellow LED
LCD	
push-buttons	



Cat. nr.	Code
BLCGPB2T	108243
Master power supply A, 200 mA from AS-i network	
30V dc	
automatic recognition (9.6 k to 12000 kbaud)	
150 μs* (number of slaves +1)	
According to DIN 19245 part 3	
Imaging of the AS-i slaves as Profibus I/O data	
Complete diagnosis and configuration via Profibus	
≥ 500V	
EN 50082, EN 50081	
IP40 (housing), IP20 (terminals)	
75 x 100 x 110 mm (DIN rail mounting)	
420 g	
0°C up to + 55°C	
- 25°C up to + 85°C	
(EEPROM) 16kB	
8 kB	
EEPROM	
1,8 ms/2 ms.	
8 kB	
1024 each	
AS-interface slaves	
PC	
Windows 3.1 up to 98	
standard software kit (SSK)	
registered software tool (BLCSS)	

Status

Power ON
PROFIBUS master recognised
Configuration error
Correct AS-i voltage
AS-i normal operation active
Automatic addressing enable
Master is in configuration mode
Slave addresses and error messages
2 (mode / set)

Connection

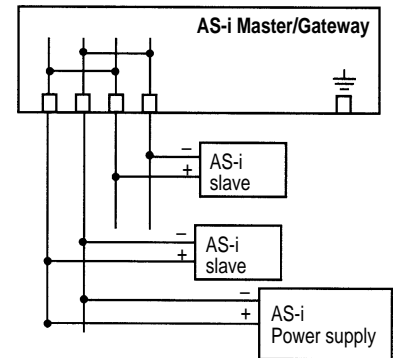

Serial interface

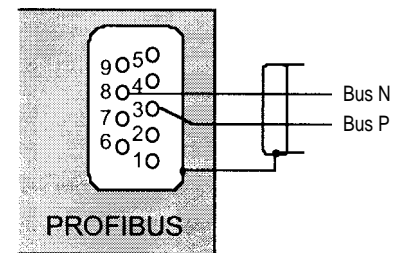

Accessories

Cat. nr.	Description
SSK	Standard software kit (free demo)
BLCSS	Registered software tool
INSMANBLCGP	AS-i/Profibus Gateways user's manual

DeviceNet Gateway

- Configuration with DeviceNet manager
- AS-i /DeviceNet gateway serves to connect the AS-i network to a superordinate DeviceNet network
- Acts as a master for the AS-i network and as a slave for the DeviceNet network



Technical data

Operating current
Operating voltage
AS-i cycle time
Insulation voltage
EMC directions
Protection degree
Dimensions (L x W x H)
Weight
Operating temperature
Storage temperature

Cat. nr.	Code
BLCGDN2T	108245
Master power supply A, 200 mA from AS-i network	
30V dc	
150 μ s* (number of slaves +1)	
\geq 500V	
EN 50082, EN 50081	
IP40 (housing), IP20 (terminals)	
75 x 100 x 110 mm (DIN rail mounting)	
420 g	
0°C up to + 55°C	
- 15°C up to + 70°C	

Connection

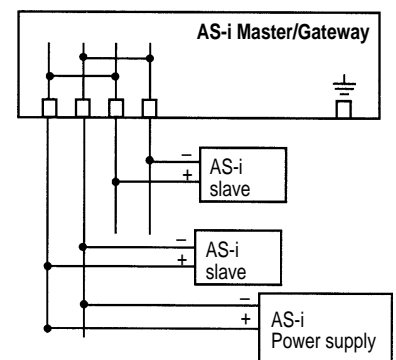

Displays

power	green LED
MNS	green/red LED
config. error	red LED
U ASI	green LED
ASI active	green LED
prg enable	green LED
prj mode	yellow LED
LCD	
push-buttons	

Status

DeviceNet voltage OK
Module/Net status
Configuration error
Correct AS-i voltage
AS-i normal operation active
Automatic addressing enable
Master is in configuration mode
Slave addresses and error messages
2 (mode / set)

Accessories

Cat. nr.	Description
INSMANBLCGD	AS-i/DeviceNet Gateway user's manual

Standard module 4 relay outputs

- Cable piercing technique
- IP67 protection degree
- Connection via AS-interface flat cable
- Standard M12 connectors
- Polarity reversal protection

Technical data

Electrical data

IO code / ID code	
total current consumption	I

External voltage supply

operation voltage range	U _B
-------------------------	----------------

Outputs

current carrying capacity	min. IL
short circuit protection	

EMC characteristics

IEC 61000-4-2	
IEC 61000-4-3	
IEC 61000-4-4	

Mechanical data

protection degree	
weight	
dimensions (H x W x D)	
shock resistance	
vibration resistance	

Temperature range

ambient temperature tolerance	T _a
storage temperature tolerance	T _s

Tightening torque

(screws used to tight the modules onto the mounting base)



Cat. nr.	Code
BLCT4AR6M	108258

8/0
≤ 60 mA
24V to 48V dc
1A
must be fused externally with 2A slow-blow

8 kV
10 V/m
1 kV/2kV

IP67
150 g
90 x 45 x 27 mm
15 g / 11 ms DIN rail mounting
30 g / 18 ms screw mounting
10 to 55 Hz / 0.5 mm. amplitude

- 25°C up to + 85°C
- 40°C up to + 85°C
0.8 Nm

Data bits

D0
D1
D2
D3

Assignment (socket)

Output OUT1 (1)
Output OUT2 (2)
Output OUT3 (3)
Output OUT4 (4)

Connection

Output socket

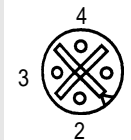

- 1: NC
- 2: NC
- 3: 0V
- 4: Switching output

External power

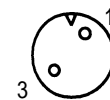

- 1: +U_B
- 3: 0V

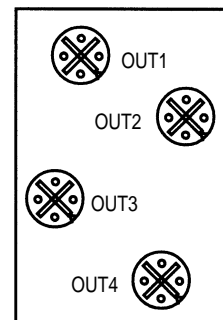

Accessories

Cat. nr.	Description
BLCTBY	Mounting base to connect the yellow AS-i flat cable (2 AS-i conductor rails)
BLCABP	Blank plugs to provide IP67 protection to unused M12 connections
BLCAGP	Gaskets to provide IP67 protection to unused flat cable connections

Standard module 2 inputs 2 relay outputs

- Cable piercing technique
- IP67 protection degree
- Connection via AS-interface flat cable
- Standard M12 connectors
- Polarity reversal protection

Technical data

Electrical data

IO code / ID code	
total current consumption	I

Inputs

low signal range	I _{in}
high signal range	U _{in} I _{in}

Sensor supply

voltage range	U _{out}
current range	I _{out}

External voltage supply

operation voltage range	U _B
-------------------------	----------------

Outputs

current carrying capacity	min. I _L
short circuit protection	

EMC characteristics

IEC 61000-4-2	
IEC 61000-4-3	
IEC 61000-4-4	

Mechanical data

protection degree	
weight	
dimensions (H x W x D)	
shock resistance	
vibration resistance	

Temperature range

ambient temperature tolerance	T _a
storage temperature tolerance	T _s

Tightening torque

(screws used to tight the modules onto the mounting base)

Data bits

D0
D1
D2
D3

Cat. nr.

BLCT2E2AR6M

Code

108969

3/0

≤ 140 mA

≤ 1.5 mA

≥ 10V

≥ 5 mA

20V to 30V dc

100 mA

24V to 48V dc

1A

must be fused externally with 2A slow-blow

8 kV

10 V/m

1 kV/2kV

IP67

150 g

90 x 45 x 27 mm

15 g / 11 ms DIN rail mounting

30 g / 18 ms screw mounting

10 to 55 Hz / 0.5 mm. amplitude

- 25°C up to + 85°C

- 40°C up to + 85°C

0.8 Nm

Assignment (socket)

Input IN1 (1)
Input IN2 (2)
Output OUT3 (3)
Output OUT4 (4)



Connection

Input socket

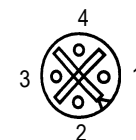

1: +
2: Input
3: -
4: Input

bridged

Output socket

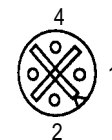

1: NC
2: NC
3: 0V
4: Switching output

External power

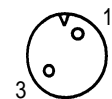

1: +U_B
3: 0V

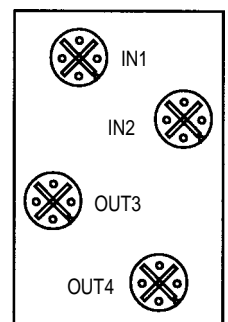

Accessories

Cat. nr.	Description
BLCTBY	Mounting base to connect the yellow AS-i flat cable (2 AS-i conductor rails)
BLCABP	Blank plugs to provide IP67 protection to unused M12 connections
BLCAGP	Gaskets to provide IP67 protection to unused flat cable connections

Standard module 2 inputs / 2 electronic outputs

- Cable piercing technique
- IP67 protection degree
- Connection via AS-interface flat cable
- Standard M12 connectors
- Polarity reversal protection

Technical data

Electrical data

IO code / ID code	3/0
total current consumption	I

Inputs

low signal range	I _{in}
high signal range	U _{in}
	I _{in}

Sensor supply

voltage range	U _{out}
current range	I _{out}

Auxiliary power supply via black cable

operation voltage range	U _B
-------------------------	----------------

Outputs

current carrying capacity	min. I _L
short-circuit protection	

EMC characteristics

IEC 61000-4-2	8 kV
IEC 61000-4-3	10 V/m
IEC 61000-4-4	1 kV/2kV

Mechanical data

protection degree	IP67
weight	150 g
dimensions (H x W x D)	90 x 45 x 27 mm
shock resistance	15 g / 11 ms DIN rail mounting 30 g / 18 ms screw mounting
vibration resistance	10 to 55 Hz / 0.5 mm. amplitude

Temperature range

ambient temperature tolerance	T _a	- 25°C up to + 85°C
storage temperature tolerance	T _s	- 40°C up to + 85°C

Tightening torque

(screws used to tight the modules onto the mounting base)



Cat. nr.	Code
BLCT2E2AS6M	108259

3/0
≤ 220 mA
≤ 1.5 mA
≥ 10V
≥ 5 mA
20V to 30V dc
120 mA
24V dc
1.4A
built-in
8 kV
10 V/m
1 kV/2kV
IP67
150 g
90 x 45 x 27 mm
15 g / 11 ms DIN rail mounting
30 g / 18 ms screw mounting
10 to 55 Hz / 0.5 mm. amplitude
- 25°C up to + 85°C
- 40°C up to + 85°C
0.8 Nm

Data bits

D0
D1
D2
D3

Assignment (socket)

Input IN1 (1)
Input IN2 (2)
Output OUT3 (3)
Output OUT4 (4)

Connection

Input socket

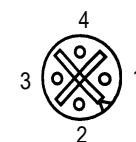

- 1: +
2: Input
3: -
4: Input
- bridged

Output socket

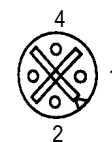

- 1: NC
2: NC
3: 0V
4: Switching output

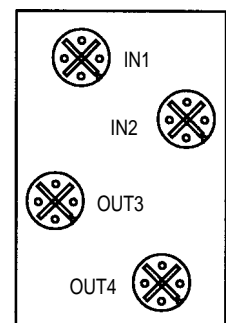

Accessories

Cat. nr.	Description
BLCTBYB	Mounting base to connect the yellow AS-i flat cable (conductor rail) and the auxiliary power black flat cable (power rail)
BLCABP	Blank plugs to provide IP67 protection to unused M12 connections
BLCAGP	Gaskets to provide IP67 protection to unused flat cable connections

Standard module 4 electronic outputs

- Cable piercing technique
- IP67 protection degree
- Connection via AS-interface flat cable
- Standard M12 connectors
- Polarity reversal protection

Technical data

Electrical data

IO code / ID code	
total current consumption	I

Auxiliary power supply via black cable

operation voltage range	U _B
-------------------------	----------------

Outputs

current carrying capacity	min. IL
short circuit protection	

EMC characteristics

IEC 61000-4-2	
IEC 61000-4-3	
IEC 61000-4-4	

Mechanical data

protection degree	
weight	
dimensions (H x W x D)	
shock resistance	
vibration resistance	

Temperature range

ambient temperature tolerance	T _a
storage temperature tolerance	T _s

Tightening torque

(screws used to tight the modules onto the mounting base)

Cat. nr.	Code
BLCT4AS6M	108257
8/0	
≤ 20 mA	
24V dc	
0.7A	
built-in	
8 kV	
10 V/m	
1 kV/2kV	
IP67	
150 g	
90 x 45 x 27 mm	
15 g / 11 ms DIN rail mounting	
30 g / 18 ms screw mounting	
10 to 55 Hz / 0.5 mm. amplitude	
- 25°C up to + 85°C	
- 40°C up to + 85°C	
0.8 Nm	

Assignment (socket)

Output OUT1 (1)
Output OUT2 (2)
Output OUT3 (3)
Output OUT4 (4)

Data bits

D0
D1
D2
D3



Connection

Input socket

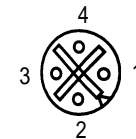

- 1: NC
- 2: NC
- 3: 0V
- 4: Switching output

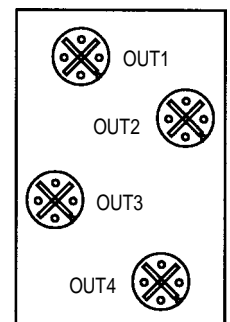

Accessories

Cat. nr.	Description
BLCTBYB	Mounting base to connect the yellow AS-i flat cable (conductor rail) and the auxiliary power black flat cable (power rail)
BLCABP	Blank plugs to provide IP67 protection to unused M12 connections
BLCAGP	Gaskets to provide IP67 protection to unused flat cable connections

Standard module 4 inputs

- Cable piercing technique
- IP67 protection degree
- Connection via AS-interface flat cable
- Standard M12 connectors
- Polarity reversal protection

Technical data

Electrical data

IO code / ID code	
total current consumption	I

Inputs

low signal range	I _{in}
high signal range	U _{in} I _{in}

Sensor supply

voltage range	U _{out}
current range	I _{out}

EMC characteristics

IEC 61000-4-2
IEC 61000-4-3
IEC 61000-4-4

Mechanical data

protection degree
weight
dimensions (H x W x D)
shock resistance
vibration resistance

Temperature range

ambient temperature tolerance	T _a
storage temperature tolerance	T _s

Tightening torque

(screws used to tight the modules onto the mounting base)



Cat. nr.	Code
BLCT4E6M	108256
IO code / ID code	0/0
total current consumption	≤ 250 mA
low signal range current	≤ 1.5 mA
high signal range voltage	≥ 10V
high signal range current	≥ 5 mA
voltage range	18V to 30V dc
current range	200 mA
IEC 61000-4-2	8 kV
IEC 61000-4-3	10 V/m
IEC 61000-4-4	1 kV / 2 kV
protection degree	IP67
weight	150 g
dimensions (H x W x D)	80 x 45 x 27 mm
shock resistance	15 g / 11 ms DIN rail mounting 30 g / 18 ms screw mounting
vibration resistance	10 to 55 Hz / 0.5 mm. amplitude
ambient temperature tolerance	- 25°C up to + 85°C
storage temperature tolerance	- 40°C up to + 85°C
Tightening torque	0.8 Nm

Data bits

D0
D1
D2
D3

Assignment (socket)

Input IN1 (1)
Input IN2 (2)
Input IN3 (3)
Input IN4 (4)

Connection

Input socket

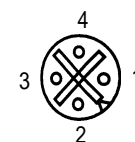

1: +
2: Input
3: -
4: Input

bridged

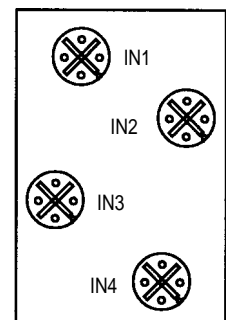

Accessories

Cat. nr.	Description
BLCTBY	Mounting base to connect the yellow AS-i flat cable (2 AS-i conductor rails)
BLCABP	Blank plugs to provide IP67 protection to unused M12 connections
BLCAGP	Gaskets to provide IP67 protection to unused flat cable connections

Flat module 4 electronic outputs

- Cable piercing technique
- Connection via AS-interface flat cable
- Only 29 mm. high, ideal for limited space applications
- Standard M12 connectors
- External power LED
- IP67 protection degree

Technical data

Electrical data

IO code / ID code	
total current consumption	I

External voltage supply (black flat cable)

operation voltage range	U _B
-------------------------	----------------

Outputs

current carrying capacity	min. I _L
	typ. I _L
total current	I _{tot}
short-circuit and indication protection	

Mechanical data

protection degree	
weight	
dimensions (H x W x D)	

Temperature range

ambient temperature tolerance	T _a
storage temperature tolerance	T _s

Tightening torque

(screws used to tight the modules onto the mounting base)

Displays

Green LED	Red LED	AUX. POWER
ON	OFF	–
OFF	OFF	–
ON	ON	–
Flashing	ON	–
ON	Flashing	–
–	–	ON
–	–	OFF

Data bits

D0	Output OUT1 (5/4)
D1	Output OUT2 (5/2; 6/4)
D2	Output OUT3 (7/4)
D3	Output OUT4 (7/2; 8/4)



Cat. nr.	Code
BLCF4AS6M	108254
8/1	
≤ 270 mA	
20V to 30V dc	
1.4A	
2A	
≤ 4A	
built-in	
IP67	
180 g	
152 x 60 x 29 mm	
– 25°C up to + 85°C	
– 40°C up to + 85°C	
1 Nm	

Status

OK
Supply error
Communication error
Address zero
Sensor overload
auxiliary power present
auxiliary power missing

Assignment (socket/pin)

Output OUT1 (5/4)
Output OUT2 (5/2; 6/4)
Output OUT3 (7/4)
Output OUT4 (7/2; 8/4)

Connection

Output socket

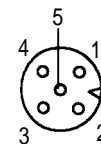

- 1: +
- 2: Output
- 3: –
- 4: Output
- 5: Ground terminal

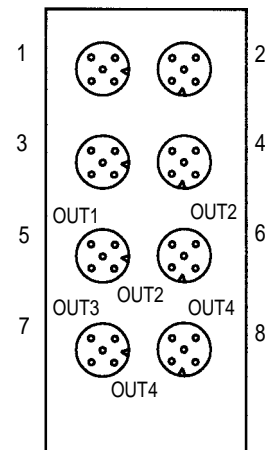

Accessories

Cat. nr.	Description
BLCAPD	Hand held addressing device
BLCAAC	Cable from module to hand held addressing device
BLCFD	Mounting base to connect the yellow AS-i flat cable and the auxiliary power black flat cable
BLCABP	Blank plugs to provide IP67 protection to unused M12 connections
BLCAGP	Gaskets to provide IP67 protection to unused flat cable connections

Flat module 2 inputs / 2 electronic outputs

- Cable piercing technique
- Connection via AS-interface flat cable
- Only 29 mm. high, ideal for limited space applications
- Standard M12 connectors
- External power LED
- IP67 protection degree



Technical data

Electrical data

IO code / ID code	
total current consumption	I

Inputs

low signal range	I _{in}
high signal range	U _{in}
	I _{in}

Sensor supply

voltage range	U _{out}
current range	I _{out}

External voltage supply (black flat cable)

operation voltage range	U _B
-------------------------	----------------

Outputs

current carrying capacity	min. I _L
	typ. I _L
total current	I _{tot}
short-circuit and indication protection	

Mechanical data

protection degree	IP67
weight	180 g
dimensions (H x W x D)	152 x 60 x 29 mm

Temperature range

ambient temperature tolerance	T _a
storage temperature tolerance	T _s

Tightening torque

(screws used to tight the modules onto the mounting base)

Displays

Green LED	Red LED	AUX. POWER
ON	OFF	–
OFF	OFF	–
ON	ON	–
Flashing	ON	–
ON	Flashing	–
–	–	ON
–	–	OFF

Data bits

D0	Input IN1 (1/4)
D1	Input IN2 (1/2; 2/4)
D2	Output OUT1 (5/4)
D3	Output OUT2 (5/2; 6/4)

Cat. nr.

Code

BLCF2E2AS6M

108255

3/1

≤ 290 mA

≤ 1.5 mA

≥ 10V

≥ 6 mA

20V to 30V dc

200 mA

20V to 30V dc

1.4A

2A

≤ 4A

built-in

IP67

180 g

152 x 60 x 29 mm

– 25°C up to + 85°C

– 40°C up to + 85°C

1 Nm

Status

OK
Supply error
Communication error
Address zero
Sensor overload
auxiliary power present
auxiliary power missing

Assignment (socket/pin)

Input IN1 (1/4)
Input IN2 (1/2; 2/4)
Output OUT1 (5/4)
Output OUT2 (5/2; 6/4)

Connection

Input/Output socket

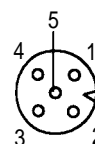

- 1: +
- 2: Input/Output
- 3: –
- 4: Input/Output
- 5: Ground terminal

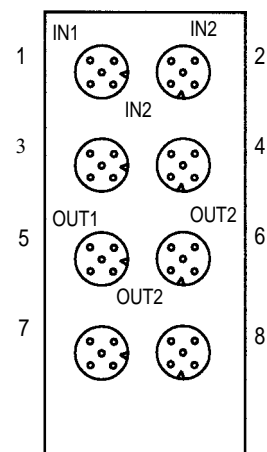

Accessories

Cat. nr.	Description
BLCAPD	Hand held addressing device
BLCAAC	Cable from module to hand held addressing device
BLCFD	Mounting base to connect the yellow AS-i flat cable and the auxiliary power black flat cable
BLCABP	Blank plugs to provide IP67 protection to unused M12 connections
BLCAGP	Gaskets to provide IP67 protection to unused flat cable connections

Flat module 4 inputs

- Cable piercing technique
- Connection via AS-interface flat cable
- Only 29 mm. high, ideal for limited space applications
- Standard M12 connectors
- IP67 protection degree

Technical data

Electrical data

IO code / ID code	
total current consumption	I

Inputs

low signal range	I _{in}
high signal range	U _{in}
	I _{in}

Sensor supply

voltage range	U _{out}
current range	I _{out}

Mechanical data

protection degree	
weight	
dimensions (H x W x D)	

Temperature range

ambient temperature tolerance	T _a
storage temperature tolerance	T _s

Tightening torque

(screws used to tight the modules onto the mounting base)

Displays

	Green LED	Red LED
	ON	OFF
	OFF	OFF
	ON	ON
	Flashing	ON
	ON	Flashing

Data bits

D0	
D1	
D2	
D3	

Cat. nr.

BLCF4E6M

Code

108253

0/1

≤ 270 mA

≤ 1.5 mA

≥ 10V

≥ 6 mA

20V to 30V dc

200 mA

IP67

180 g

152 x 60 x 29 mm

– 25°C up to + 85°C

– 40°C up to + 85°C

1 Nm

Status

OK
Supply error
Communication error
Address zero
Sensor overload

Assignment (socket/pin)

Input IN1 (1/4)
Input IN2 (1/2; 2/4)
Input IN3 (3/4)
Input IN4 (3/2; 4/4)



Connection

Input/ socket

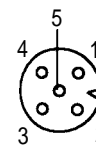

- 1: +
- 2: Input/
- 3: -
- 4: Input
- 5: Ground terminal

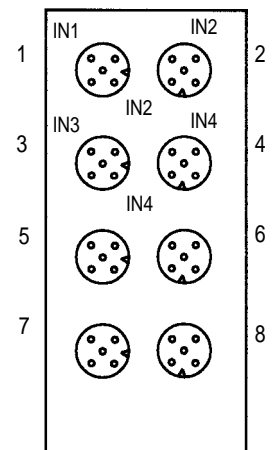

Accessories

Cat. nr.	Description
BLCAPD	Hand held addressing device
BLCAAC	Cable from module to hand held addressing device
BLCFD	Mounting base to connect the yellow AS-i flat cable and the auxiliary power black flat cable
BLCABP	Blank plugs to provide IP67 protection to unused M12 connections
BLCAGP	Gaskets to provide IP67 protection to unused flat cable connections

Flat module 4 inputs / 4 electronic outputs

- Cable piercing technique
- Connection via AS-interface flat cable
- Only 29 mm. high, ideal for limited space applications
- Standard M12 connectors
- External power LED
- IP67 protection degree



Technical data

Electrical data

IO code / ID code	
total current consumption	I

Inputs

low signal range	I _{in}
high signal range	U _{in}
	I _{in}

Sensor supply

voltage range	U _{out}
current range	I _{out}

External voltage supply (black flat cable)

operation voltage range	U _B
-------------------------	----------------

Outputs

current carrying capacity	min. I _L	1.4A
	typ. I _L	2A
total current	I _{tot}	≤ 4A
short-circuit and indication protection		built-in

Mechanical data

protection degree	IP67
weight	180 g
dimensions (H x W x D)	152 mm x 60 mm x 29 mm

Temperature range

ambient temperature tolerance	T _a	- 25°C up to + 85°C
storage temperature tolerance	T _s	- 40°C up to + 85°C

Tightening torque

(screws used to tight the modules onto the mounting base)

Displays

Green LED	Red LED	AUX. POWER
ON	OFF	-
OFF	OFF	-
ON	ON	-
Flashing	ON	-
ON	Flashing	-
-	-	ON
-	-	OFF

Data bits

D0	
D1	
D2	
D3	

Cat. nr.

BLCF4E4AS6M

Code

108251

7/F

≤ 270 mA

≤ 1.5 mA

≥ 10V

≥ 6 mA

20V to 30V dc

200 mA

20V to 30V dc

1.4A

2A

≤ 4A

built-in

IP67

180 g

152 mm x 60 mm x 29 mm

- 25°C up to + 85°C

- 40°C up to + 85°C

1 Nm

Status

OK

Supply error

Communication error

Address zero

Sensor overload

auxiliary power present

auxiliary power missing

Assignment (socket/pin)

Input IN1 (1/4)	Output OUT1 (5/4)
Input IN2 (1/2; 2/4)	Output OUT2 (5/2; 6/4)
Input IN3 (3/4)	Output OUT3 (7/4)
Input IN4 (3/2; 4/4)	Output OUT4 (7/2; 8/4)

Connection

Input/Output socket

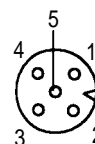

- 1: +
- 2: Input/Output
- 3: -
- 4: Input/Output
- 5: Ground terminal

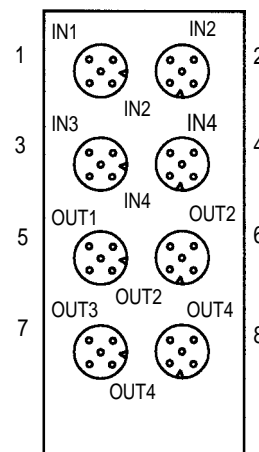

Accessories

Cat. nr.	Description
BLCAPD	Hand held addressing device
BLCAAC	Cable from module to hand held addressing device
BLCFD	Mounting base to connect the yellow AS-i flat cable and the auxiliary power black flat cable
BLCABP	Blank plugs to provide IP67 protection to unused M12 connections
BLCAGP	Gaskets to provide IP67 protection to unused flat cable connections

Flat module 8 inputs

- Cable piercing technique
- Connection via AS-interface flat cable
- Only 29 mm. high, ideal for limited space applications
- Standard M12 connectors
- IP67 protection degree

Technical data

Electrical data

IO code / ID code	
total current consumption	I

Inputs

low signal range	I _{in}
high signal range	U _{in}
	I _{in}

Sensor supply

voltage range	U _{out}
current range	I _{out}

Mechanical data

protection degree	
weight	
dimensions (H x W x D)	

Temperature range

ambient temperature tolerance	T _a
storage temperature tolerance	T _s

Tightening torque

(screws used to tight the modules onto the mounting base)

Displays

	Green LED	Red LED
	ON	OFF
	OFF	OFF
	ON	ON
	Flashing	ON
	ON	Flashing

Data bits

D0	
D1	
D2	
D3	

Cat. nr.

BLCF8E6M

Code

108252

0/1

≤ 290 mA

≤ 1.5 mA

≥ 10V

≥ 6 mA

20V to 30V dc

200 mA

IP67

180 g

152 x 60 x 29 mm

- 25°C up to + 85°C

- 40°C up to + 85°C

1 Nm

Status

OK
Supply error
Communication error
Address zero
Sensor overload

Assignment (socket/pin)

Input IN1 (1/4)	Input IN1 (5/4)
Input IN2 (1/2; 2/4)	Input IN2 (5/2; 6/4)
Input IN3 (3/4)	Input IN3 (7/4)
Input IN4 (3/2; 4/4)	Input IN4 (7/2; 8/4)



Connection

Input/ socket

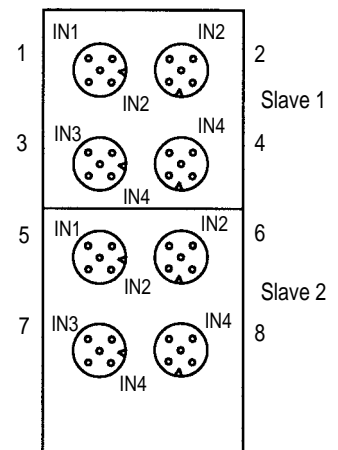
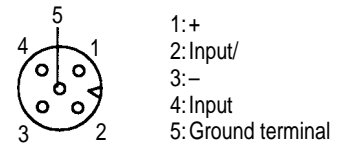

Accessories

Cat. nr.	Description
BLCPD	Hand held addressing device
BLCAAC	Cable from module to hand held addressing device
BLCFD	Mounting base to connect the yellow AS-i flat cable and the auxiliary power black flat cable
BLCABP	Blank plugs to provide IP67 protection to unused M12 connections
BLCAGP	Gaskets to provide IP67 protection to unused flat cable connections

Slim module 2 inputs / 2 relay outputs

- Special solution for control cabinets
- Usefull with 35 mm DIN rail EN50022
- 22.5 mm assembly width
- Valid addresses 01 to 31 (each address may be used only once)

Technical data

Electrical data

IO code / ID code	
total current consumption	I

Inputs

low signal range	I _{in}
high signal range	U _{in}
	I _{in}

Sensor supply

voltage range	U _{out}
---------------	------------------

Outputs

current carrying capacity	I _{th}
short-circuit protection	

EMC characteristics

IEC 61000-4-2	
IEC 61000-4-3	
IEC 61000-4-4	

Mechanical data

protection degree	
weight	
dimensions (H x W x D)	
shock resistance	
vibration resistance	

Temperature range

ambient temperature tolerance	T _a
storage temperature tolerance	T _s

The module's address can be changed 15 times, after that it keeps the last address

Displays

	Green LED	Red LED
	ON	OFF
	OFF	ON
	Flashing	ON

Data bits

D0	
D1	
D2	
D3	

Cat. nr.

BLCM2E2AR2T

Code

108250

3/0

≤ 50 mA

≤ 1.5 mA

≥ 10V

≥ 5 mA

20V to 30V dc

6A

6A gL/gG

8 kV

10V/m

1kV/2kV

IP20

160 g

102 x 22.5 x 92 mm

15 g / 11 ms

10 to 55 Hz / 0.5 mm amplitude

- 25°C up to + 60°C

- 40°C up to + 85°C

Status

OK

Communication error

Address zero

Assignment

Input IN1	
Input IN2	
Output OUT1	
Output OUT2	



Connection

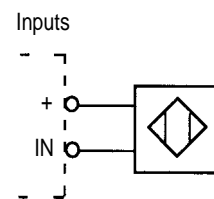
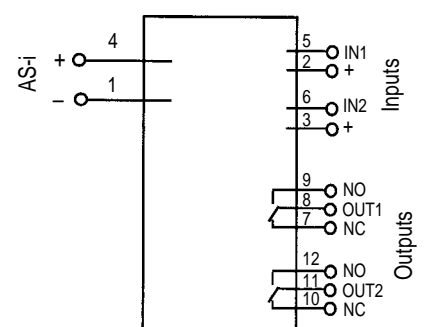

Accessories

Cat. nr.	Description
BLCAPD	Hand held addressing device
BLCAAC	Cable from module to hand held addressing device

Slim module 2 inputs / 2 electronic outputs

- Special solution for control cabinets
- Usefull with 35 mm DIN rail EN50022
- 22.5 mm assembly width
- Valid addresses 01 to 31 (each address may be used only once)

Technical data

Electrical data

IO code / ID code	
total current consumption	I

Inputs

low signal range	I _{in}
high signal range	U _{in}
	I _{in}

Sensor supply

voltage range	U _{out}
---------------	------------------

External voltage supply

operating voltage range	U _B
-------------------------	----------------

Outputs

current carrying capacity	min. I _{th}	1.4A
	typ. I _L	2A
total current of all outputs	I _{tot}	≤ 4A
short-circuit and induction protection		built-in

EMC characteristics

IEC 61000-4-2	8 kV
IEC 61000-4-3	10V/m
IEC 61000-4-4	1kV/2kV

Mechanical data

protection degree	IP20
weight	130 g
dimensions (H x W x D)	102 x 22.5 x 92 mm
shock resistance	15 g / 11 ms
vibration resistance	10 to 55 Hz / 0.5 mm amplitude

Temperature range

ambient temperature tolerance	T _a	- 25°C up to + 70°C
storage temperature tolerance	T _s	- 40°C up to + 85°C

The module's address can be changed 15 times, after that it keeps the last address

Displays

	Green LED	Red LED
	ON	OFF
	OFF	ON
	Flashing	ON

Data bits

D0	
D1	
D2	
D3	

Cat. nr.

BLCM2E2AS2T

Code

108248

3/0

≤ 50 mA

≤ 1.5 mA

≥ 10V

≥ 5 mA

20V to 30V dc

20V to 30V dc

1.4A

2A

≤ 4A

built-in

8 kV

10V/m

1kV/2kV

IP20

130 g

102 x 22.5 x 92 mm

15 g / 11 ms

10 to 55 Hz / 0.5 mm amplitude

- 25°C up to + 70°C

- 40°C up to + 85°C

Status

OK

Communication error

Address zero

Assignment

Input IN1

Input IN2

Output OUT1

Output OUT2



Connection

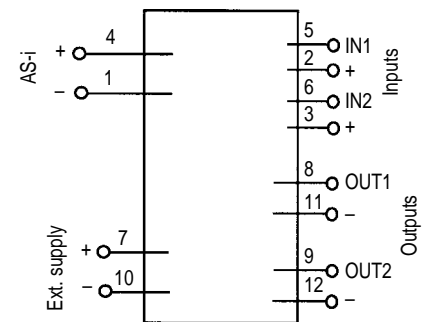

Inputs

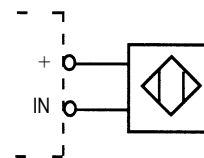

Outputs

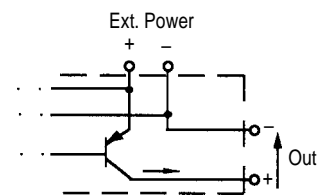

Accessories

Cat. nr.	Description
BLCAPD	Hand held addressing device
BLCAAC	Cable from module to hand held addressing device

Slim module 4 inputs

- Special solution for control cabinets
- Usefull with 35 mm Din rail EN50022
- 22.5 mm assembly width
- Valid addresses 01 to 31 (each address may be used only once)

Technical data

Electrical data

IO code / ID code	
total current consumption	I

Inputs

low signal range	I _{in}
high signal range	U _{in}
	I _{in}

Sensor supply

voltage range	U _{out}
current range	I _{out}

Mechanical data

protection degree	
weight	
dimensions (H x W x D)	
shock resistance	
vibration resistance	

Temperature range

ambient temperature tolerance	T _a
storage temperature tolerance	T _s

The module's address can be changed 15 times, after that it keeps the last address

Displays

	Green LED	Red LED
	ON	OFF
	OFF	ON
	Flashing	ON
	OFF	Flashing

Data bits

D0
D1
D2
D3

Cat. nr.

BLCM4E2T

Code

108246

0/0

≤ 270 mA

≤ 1.5 mA

≥ 10V

≥ 5 mA

20V to 30V dc

200 mA

IP20

150 g

102 x 22.5 x 92 mm

15 g / 11 ms

10 to 55 Hz / 0.5 mm amplitude

- 25°C up to + 70°C

- 40°C up to + 85°C

Status

OK
Communication error
Address zero
Sensor overload

Assignment

Input IN1
Input IN2
Input IN3
Input IN4



Connection

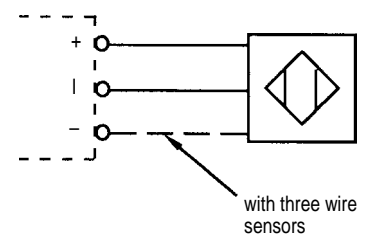
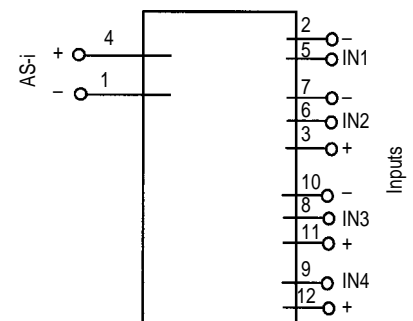

Accessories

Cat. nr.	Description
BLCAPD	Hand held addressing device
BLCAAC	Cable from module to hand held addressing device

Slim module 4 inputs / 4 electrical outputs

- Special solution for control cabinets
- Usefull with 35 mm DIN rail EN50022
- 45 mm assembly width
- Valid addresses 01 to 31 (each address may be used only once)

Technical data

Electrical data

IO code / ID code	
total current consumption	I

Inputs

low signal range	I _{in}
high signal range	U _{in}
	I _{in}

Sensor supply

voltage range	U _{out}
current range	I _{out}

External voltage supply

operating voltage range	U _B
-------------------------	----------------

Outputs

current carrying capacity	min. I _{th}
	typ. I _L
total current of all outputs	I _{tot}
short-circuit and induction protection	

EMC characteristics

IEC 61000-4-2	
IEC 61000-4-3	
IEC 61000-4-4	

Mechanical data

protection degree	
weight	
dimensions (H x W x D)	
shock resistance	
vibration resistance	

Temperature range

ambient temperature tolerance	T _a
storage temperature tolerance	T _s

The module's address can be changed 15 times, after that it keeps the last address

Displays

	Green LED	Red LED
	ON	OFF
	OFF	ON
	Flashing	ON
	OFF	Flashing

Data bits	Assignment
D0	Input IN1
D1	Input IN2
D2	Input IN3
D3	Input IN4



Cat. nr. **BLCM4E4AS2T** Code 108249

7/0	
≤ 270 mA	
≤ 1.5 mA	
≥ 10V	
≥ 5 mA	
20V to 30V dc	
200 mA	
20V to 30V dc	
1.4A	
2A	
≤ 4A	
built-in	
8 kV	
10V/m	
1kV/2kV	
IP20	
280 g	
102 x 45 x 91.4 mm	
15 g / 11 ms	
5 to 500 Hz	
- 25°C up to + 70°C	
- 40°C up to + 85°C	

Status

OK	
Communication error	
Address zero	
Sensor overload	

Data bits	Assignment
D0	Output OUT1
D1	Output OUT2
D2	Output OUT3
D3	Output OUT4

Connection

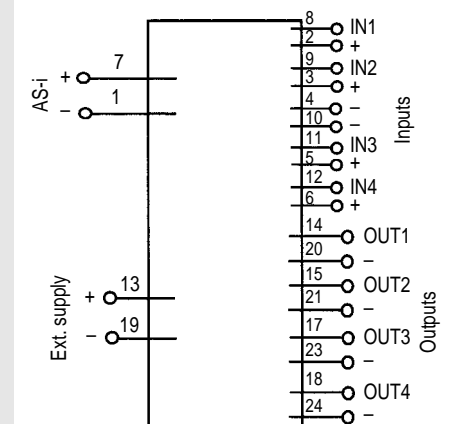

Inputs

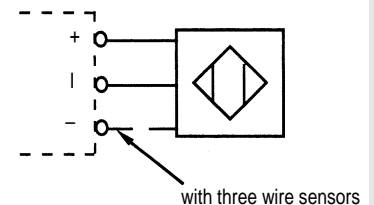

Outputs

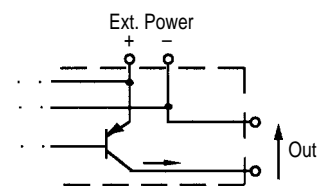

Accessories

Cat. nr.	Description
BLCAPD	Hand held addressing device
BLCAAC	Cable from module to hand held addressing device

Slim module 4 inputs / 4 relay outputs

- Special solution for control cabinets
- Usefull with 35 mm DIN rail EN50022
- 45 mm assembly width
- Valid addresses 01 to 31 (each address may be used only once)

Technical data

Electrical data

IO code / ID code	
total current consumption	I

Inputs

low signal range	I _{in}
high signal range	U _{in}
	I _{in}

Sensor supply

voltage range	U _{out}
current range	I _{out}

Outputs

current carrying capacity	min. I _{th}
total current of all outputs	I _{tot}
short-circuit protection	

EMC characteristics

IEC 61000-4-2	
IEC 61000-4-3	
IEC 61000-4-4	

Mechanical data

protection degree	IP20
weight	290 g
dimensions (H x W x D)	102 x 45 x 91.4 mm
shock resistance	15 g / 11 ms
vibration resistance	5 to 500 Hz

Temperature range

ambient temperature tolerance	T _a	- 25°C up to + 60°C
storage temperature tolerance	T _s	- 40°C up to + 85°C

The module's address can be changed 15 times, after that it keeps the last address

Displays

	Green LED	Red LED
	ON	OFF
	OFF	ON
	Flashing	ON
	OFF	Flashing

Data bits	Assignment
D0	Input IN1
D1	Input IN2
D2	Input IN3
D3	Input IN4



Cat. nr. Code

BLCM4E4AR2T 108968

7/0

≤ 270 mA

≤ 1.5 mA

≥ 10V

≥ 5 mA

20V to 30V dc

200 mA

5A

1A (24V)

6A gL/gG

8 kV

10V/m

1kV/2kV

IP20

290 g

102 x 45 x 91.4 mm

15 g / 11 ms

5 to 500 Hz

- 25°C up to + 60°C

- 40°C up to + 85°C

Status

OK
Communication error
Address zero
Sensor overload

Data bits	Assignment
D0	Output OUT1
D1	Output OUT2
D2	Output OUT3
D3	Output OUT4

Connection

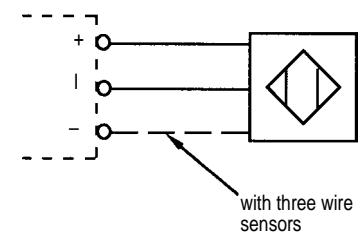
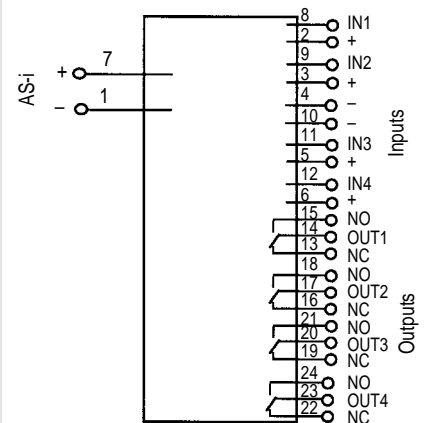

Accessories

Cat. nr.	Description
BLCAPD	Hand held addressing device
BLCAAC	Cable from module to hand held addressing device

Slim module 4 electronic outputs

- Special solution for control cabinets
- Usefull with 35 mm DIN rail EN50022
- 22.5 mm assembly width
- Valid addresses 01 to 31 (each address may be used only once)

Technical data

Electrical data

IO code / ID code	
total current consumption	I

External voltage supply

operating voltage range	U _B
-------------------------	----------------

Outputs

current carrying capacity	min. I _L
	typ. I _L
short-circuit and induction protection	

EMC characteristics

IEC 61000-4-2
IEC 61000-4-3
IEC 61000-4-4

Mechanical data

protection degree
weight
dimensions (H x W x D)
shock resistance
vibration resistance

Temperature range

ambient temperature tolerance	T _a
storage temperature tolerance	T _s

The module's address can be changed 15 times, after that it keeps the last address

Displays

	Green LED	Red LED
	ON	OFF
	OFF	ON
	Flashing	ON

Data bits

D0
D1
D2
D3

Cat. nr.

BLCM4AS2T

Code

108247

8/0

≤ 40 mA

20V to 30V dc

0.7A

1.0A

built-in

8 kV

10V/m

1kV/2kV

IP20

150 g

102 x 22.5 x 92 mm

15 g / 11 ms

10 to 55 Hz / 0.5 mm amplitude

- 25°C up to + 70°C

- 40°C up to + 85°C

Status

OK
Communication error
Address zero

Assignment

Output OUT1
Output OUT2
Output OUT3
Output OUT4



Connection

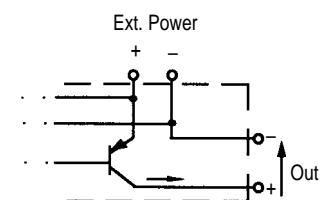
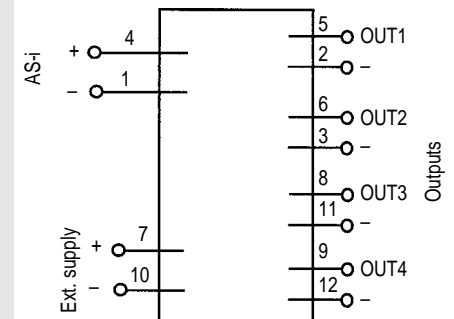

Accessories

Cat. nr.	Description
BLCAPD	Hand held addressing device
BLCAAC	Cable from module to hand held addressing device

Standard bases

Standard base for two yellow flat cables
(BLCTBYY)

Standard base for yellow + black flat cables
(BLCTBYB)

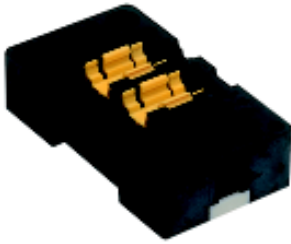

Cat. nr.	Code
BLCTBYY/BLCTBYB	108271/108272

Technical data

- Connection by insulation piercing technique automatically when a user module or a cover is screwed onto it
- To be screwed or snapped onto a standard mounting rail
- Mechanically coded to avoid reverse connection of the user module or cover
- Not used cable openings shall be closed by rubber gaskets (see p. 32)
- Fit the AS-i flat cables in the colourcoded guides. **Do not reverse the yellow and black conductor rail, otherwise the user module will be destroyed.**

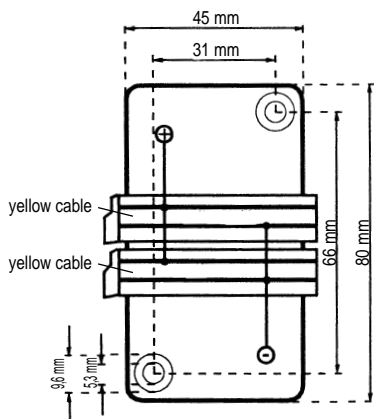
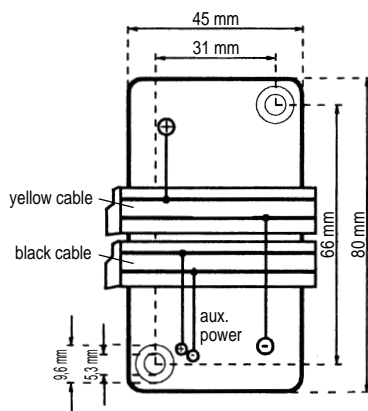

Mounting plate

Flat mounting plate for yellow + black cables



Cat. nr.	Code
BLCFD	108269

Technical data

- Mounting plate is fitted to the module with one screw only
- Connection by insulation penetration technique is ensured automatically when fitting the module onto the mounting plate
- Not used cable openings shall be closed by rubber gaskets (see p. 32)
- Coding facility to avoid errors during replacement
- Fit the AS-i flat cables in the colourcoded guides. **Do not reverse the yellow and black conductor rail, otherwise the user module will be destroyed.**

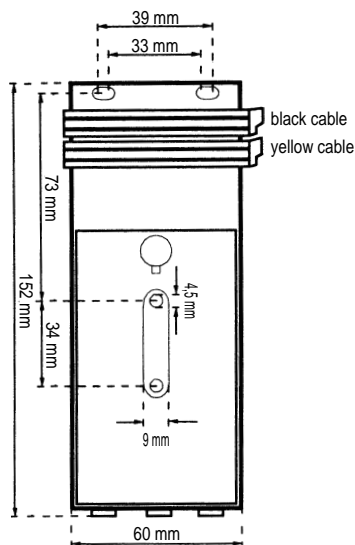

Power supply 2.4A & 7A

- Connected at any point of the AS-i network
- Recommended to be connected where the current consumption is relatively high
- Compliance with standards EN 60950 (VDE 0805)

Technical data

Nominal input voltage
Operating input voltage range
Nominal input frequency
Operating input frequency range
Buffering
Primary back-up fuse
Nominal input current
Nominal output voltage
Output tolerance
Output residual ripple
Efficiency
Rated output
Nominal output current
Ambient temperature
Short-circuit protection
Safety class
Electrical isolation
Radio interference suppression
Protection degree

Connection



Cat. nr.	Code
BLCP24LP	108267
120/230V ac (switchable) factory setting 230V ac*	
102 to 132V / 195 to 253V	
50/60 Hz	
47 to 63 Hz	
≥ 20 ms	
2 AT	
-	
30V dc	
29.5 up to 31.6V	
< 150 mV _{pp}	
> 80%	
72 W	
2.4A	
55°C	
automatic restart	
1	
SELV to EN 60950	
Class B (EN 55011)	
-	

* Before setting the unit into operation, please check that it has been set to the correct main voltage

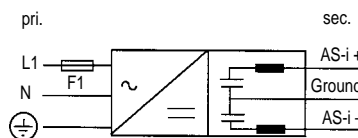

Terminals wire range (PRI): 0.2 up to 2.5 mm²
 Insulation stripping length: 7 mm
 Terminals wire range (SEC): 0.2 up to 4 mm²
 Insulation stripping length: 7 mm
 Tightening torque: 0.5 up to 0.6 Nm



Cat. nr.	Code
BLCP7HP	108268
230V ac	
187 to 264V	
50/60 Hz	
47 to 63 Hz	
≥ 20 ms	
-	
1.7A	
30V dc	
± 1%	
< 150 mV _{pp}	
approx. 85%	
210 W	
7A	
0°C to 60°C	
automatic restart	
1	
SELV to EN 60950	
Class B (EN 55011)	
IP20	

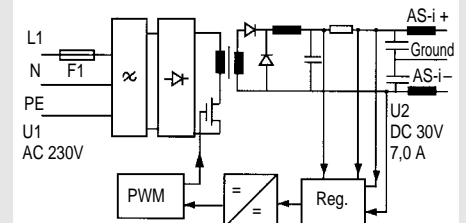

Terminals wire range: 0.08 up to 2.5 mm²
 Insulation stripping length: 5 up to 6 mm

Connect the lead by operating the button to the left of the lead, and at the same time insert the lead

Repeater

- The repeater is used to extend an existing AS-i line by up to 100 m
- No address is required to connect the repeater to the line
- The total number of slaves addressable is not modified (31 slaves per master)
- Slaves can be connected to the line before and behind the repeater
- Two power supplies are required to operate
- No more than 2 consecutive repeaters allowed (max. total length 300 m)

Cat. nr.	Code
BLCAR	108970
Technical data	
Connections	AS-i interface flat cable
Operating voltage	from AS-i interface
Operating current	60 mA per network segment; 120 mA total
Response time	6 μ s per telegram and transmission direction 12 μ s total
EMC classification	severity level 3, IEC 801.2-4
Operating temperature	0 up to + 55°C
Storage temperature	- 25°C up to + 75°C
Housing material	plastic
Protection degree	IP65



Connection

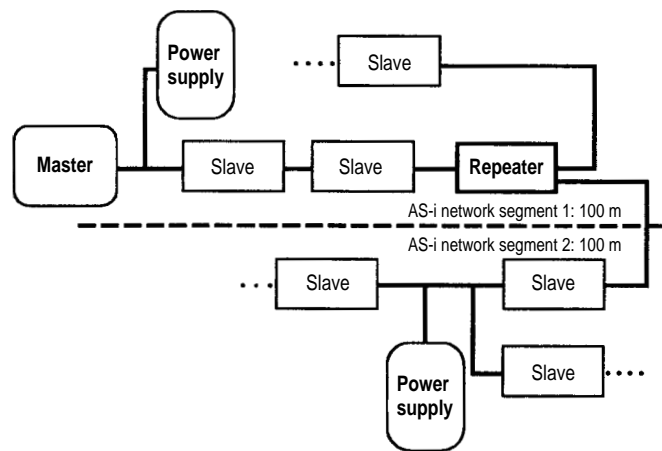

Tree topology (cover only)



BLCAPCTT

108266

Passive connection to allow tree topology
Connectable to standard base for two yellow
cables (BLCTBY)

M12 angular coupling plug



BLCAACP

107129

Passive connection flat cable to M12



BLCAPCM12

108265

Passive connection from the yellow or black AS-i
flat cable to M12

Blank plugs



BLCABP

108270

M12 plugs to provide IP67 protection to unused I/O

M12 straight coupling plug



BLCASCP

107128

Rubber gaskets



BLCAGP

108971

Rubber gaskets to protect (close) unused cable
openings in standard bases and flat mounting
plates

Cable

- Insulation penetration technique
- Self-sealing
- Resistant against environmental effects
- Small bending radius
- Cable geometry ensures polarity reversal protection

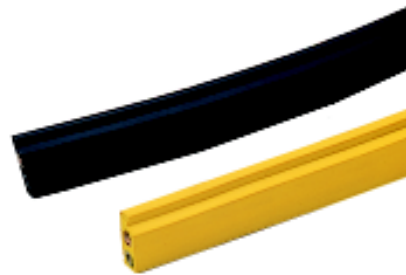

Technical data

	Cat. nr.	Code
Yellow cable	BLCAYC	108261
Black cable	BLCABC	108262
Coding example	AS-interface line	
Nominal voltage U ₀	AS-interface line for external supply voltage, up to 24V, oil resistant	
No. of conductors	100 m ring	
Nominal cross section	two-wire, flat rubber sheathed cable with yellow or black rubber sheathing	
Conductors	30V	
Insulating covering	1.5 mm ² two-wire	
Conductor coding	Tin-plated copper, extra-fine strand, class 6 accord. to DIN VDE 0295	
Conductor arrangement	Rubber mixture accord. to DIN 0207 part 20	
Jacket	1 conductor brown, 1 conductor blue 1 conductor imprinted: X KABELMETAL X	
Limiting temperatures	Parallel, brown conductor lies on the side with the coding strip	
on conductor	Rubber mixture EM3 accord. DIN VDE 0207 part 21, dimensions accord. Fig. 1	
operation	Jacket color yellow (similar RAL 1012) or black (similar RAL 9005)	
short-circuit	For operation, wiring, transport and storage	
directly on the surface	+ 90°C	
moving, when wiring	+ 200°C	
Maximum tensile load	– 40°C up to + 85°C	
Minimum allowable curvature	– 25°C up to + 85°C	
Power rating	Accord. DIN VDE 0298 part 3. 50 N/mm ² conductor cross section when wiring	
Tests	According to DIN VDE 0298 part 3, Table 2 bending load allowed only to the flat cable side	
Electrical tests	Acc. to DIN VDE 0298 part 4, Table 6, column 4	
T, F conductor resistance	T = type test	
T, F electrical strength (test on the complete conductor)	F = selection test	
Electrical tests	S = routine check test	
T, F conductor resistance	Requirements	
T, F electrical strength (test on the complete conductor)	DIN VDE 0295	
	no arcing	
	conductor lest length 20 m	
	length of water storage min. 1 h	
	temperature of the water bath (20 ± 5)°C	
	test voltage (AC) 1.8 kV	
	test duration 5 min.	
	Tests accord. to	
	DIN VDE 0472 part 501	
	DIN VDE 0472, part 50	
	test type A	

Address programming device

- Determining the slave address
- New addressing with check
- Slave connection is short-circuit and overload proof
- LCD-display error analysis

Technical data

Display	LCD, 13 mm number height
Keypad	membrane keypad, 4 keys
Interface	AS-i, short-circuit and overload proof
Power supply	accumulator operation, use only the included charging device for charging (charging time approx. 14 h)
Charging device	115/230V ac, plug-in charger, incl. units shipment
Operating time	8 h / > 250 read/write procedures with fully charged accumulator
Type of protection according to EN 60 529	IP20
Operating temperature	0°C up to + 50°C
Storage temperature	- 20°C up to + 55°C
Weight	approx. 550 g
Dimensions (W x H x D)	80 x 30 x 209 mm

Addressing cable

Cat. nr. **BLCAAC**
Code 108264

Auxiliary cable to be used with the addressing device.



Cat. nr.	Code
BLCAPD	108263
Display	LCD, 13 mm number height
Keypad	membrane keypad, 4 keys
Interface	AS-i, short-circuit and overload proof
Power supply	accumulator operation, use only the included charging device for charging (charging time approx. 14 h)
Charging device	115/230V ac, plug-in charger, incl. units shipment
Operating time	8 h / > 250 read/write procedures with fully charged accumulator
Type of protection according to EN 60 529	IP20
Operating temperature	0°C up to + 50°C
Storage temperature	- 20°C up to + 55°C
Weight	approx. 550 g
Dimensions (W x H x D)	80 x 30 x 209 mm

key ↑ = increment slave address
key ↓ = decrement slave address
key PRG = program a new slave address
key ADR = read the slave address/switch on device

Display

The LCD displays shows the address or an error code.

Error codes

F1 = overload of the AS-i power supply
F2 = slave connected or faulty
F3 = slave programming error
LOBAT = **charge accumulator!** Approx. 30 read and addressing procedures are possible after this indicator appears. Charge the accumulator only using the charger shipped with the device.

Status display

÷ = the displayed address is identical to the last set or programmed slave address.

Operation

The device is switched on using the "ADR" key. It switched off automatically if no operations are carried out after approx. one minute.

- Each time the "ADR" key is pressed, the current slave address appears in the display.
- Using the two keys "↑" and "↓", the address to be programmed is selected from the address ring (i.e. 31 ... 0 ... 31). Pressing a key steps through the individual addresses, pressing and holding a key continuously scrolls through the address (0.5 s per address).
- Pressing the key "PRG" loads the new address into the slave. If no errors occur, the programmed address automatically appears in the display after approx. 0.5 s (the display is empty during this time).
- By pressing and holding the "ADR" and "PRG" keys, the address 0 is automatically programmed into the slave.
- All other key combinations perform no action.

Important!

Charge accumulator before initial commissioning.



Control software

Software for configuration, programming and diagnostics

Cat. nr.	Code
SSK	108273

AS-i Control software basis version:
600 Kbytes program memory for AS-i Control

BLCSS	108274
--------------	--------

AS-i Control software: 16 Kbytes program
memory for AS-i Control with additional advanced
diagnostics

General information

- Operating system: MS-Windows (from version 3.1 up to 98)
- Comprehensible operator guidance
- Simple installation
- Language: English/German
- Extensive help menu

AS-i configuration editor

Tool for the commissioning of AS-interface

- Graphical display of the AS-i network
Alternative plain text display of the AS-i network
 - Many devices icons out of an icon archive
 - Simple embedding of own icons and devices
- Display of the actual configuration on the AS-interface (slave-profiles in plain language)
- Comparison of actual configuration with the projected one
- Programming of slave addresses
- Projecting of the actual configuration
- Reading of inputs
- Writing of outputs
- Writing of parameters
- Projecting of individual slaves (Offline/Online)
- Slave can be given its own name

AS-i Master identity program control

- Reading and writing of AS-i Master and AS-i control flags
- Programming language IL
- Extensive simulation and debug tools by means of graphic display of the inputs and outputs, timers, counters and flags
- Forcing of process data
- Programming syntax check, download/upload, start/stop

Advanced AS-i Diagnostics

- Display of AS-i slaves which caused configuration errors
- Judgement of the quality of the AS-i communication by means of error counters for every AS-i slave

AS-i address assistant

- Automatic address of the AS-interface slaves (no handheld necessary)

Other functions

- Offline/online mode
- Open and save of AS-interface configuration files
- Open and save of AWL-files

Can be used with the following AS-i Masters

- AS-i Master with RS485
- AS-i PC board
- AS-i Profibus gateway

Included manuals

- "AS-i Control for Masters and Gateways": shows how to program and configurate an application

INSMANSOFT1	108912
--------------------	--------

- "AS-i Control software user's manual": instruction manual to use the software application

INSMANSOFT2	108913
--------------------	--------



Cat. nr.	Code	Page
BLCAAC	108264	19
BLCABC	108262	33
BLCABP	108270	32
BLCAGP	108971	32
BLCAPCM12	108265	32
BLCAPCTT	108266	32
BLCAPD	108263	18
BLCAR	108970	31
BLCARS4	108911	31
BLCAACP	107129	32
BLCASCP	107128	32
BLCAYC	108261	33
BLCCD2T	108240	7
BLCCPCBT	108241	8
BLCCS2T	108239	6
BLCF2E2AS6M	108255	19
BLCF4AS6M	108254	18
BLCF4E4AS6M	108251	21
BLCF4E6M	108253	20
BLCF8E6M	108252	22
BLCFD	108269	29
BLCGDN2T	108245	12
BLCGPB2T	108243	10
BLCGPB6T	108244	11
BLCM2E2AR2T	108250	23
BLCM2E2AS2T	108248	24
BLCM4AS2T	108247	28
BLCM4E2T	108246	25
BLCM4E4AR2T	108968	27
BLCM4E4AS2T	108249	26
BLCP24LP	108267	30
BLCP7HP	108268	30
BLCSS	108274	6
BLCT2E2AR6M	108969	14
BLCT2E2AS6M	108259	15
BLCT4AR6M	108258	13
BLCT4AS6M	108257	16
BLCT4E6M	108256	17
BLCTBYB	108272	29
BLCTBYY	108271	29
BLCTBYY	108271	29
IC200BEM104	-	9
IC200CHI006B	165614	9
INSMANBLCC	108914	6
INSMANBLCGD	108916	12
INSMANBLCGP	108917	9
INSMANPC	108915	8
INSMANSOFT1	108912	35
INSMANSOFT2	108913	35
SSK	108273	6

Code	Cat. nr.	Page
107128	BLCAACP	32
107129	BLCASCP	32
108239	BLCCS2T	6
108240	BLCCD2T	7
108241	BLCCPCBT	8
108243	BLCGPB2T	10
108244	BLCGPB6T	11
108245	BLCGDN2T	12
108246	BLCM4E2T	25
108247	BLCM4AS2T	28
108248	BLCM2E2AS2T	24
108249	BLCM4E4AS2T	26
108250	BLCM2E2AR2T	23
108251	BLCF4E4AS6M	21
108252	BLCF8E6M	22
108253	BLCF4E6M	20
108254	BLCF4AS6M	18
108255	BLCF2E2AS6M	19
108256	BLCT4E6M	17
108257	BLCT4AS6M	16
108258	BLCT4AR6M	13
108259	BLCT2E2AS6M	15
108261	BLCAYC	33
108262	BLCABC	33
108263	BLCAPD	18
108264	BLCAAC	19
108265	BLCAPCM12	32
108266	BLCAPCTT	32
108267	BLCP24LP	30
108268	BLCP7HP	30
108269	BLCFD	29
108270	BLCABP	32
108271	BLCTBYY	29
108271	BLCTBYY	29
108272	BLCTBYB	29
108273	SSK	6
108274	BLCSS	6
108911	BLCARS4	31
108912	INSMANSOFT1	35
108913	INSMANSOFT2	35
108914	INSMANBLCC	6
108915	INSMANPC	8
108916	INSMANBLCGD	12
108917	INSMANBLCGP	9
108968	BLCM4E4AR2T	27
108969	BLCT2E2AR6M	14
108970	BLCAR	31
108971	BLCAGP	32
165614	IC200CHI006B	9

The policy of GE Power Controls is one of continuous improvement. The right is reserved to alter the design or any structural details of the products at any time without giving notice.



We bring good things to life.

GE Power Controls in Europe

GE Power Controls is the European arm of GE Industrial Systems, one of the ten core businesses of the General Electric Company (USA), known internationally for its positive approach to its customers, its people and the world we all live in.

GE Power Controls is a top class European supplier of low-voltage products including wiring devices, residential and industrial electrical distribution components, general purpose control products, enclosures and switchboards. Most of the global demand for the company's products comes from OEMs, wholesalers, installers and panel-board builders worldwide.

So, these are the facts, now the story behind them. GE Power Controls' name is synonymous with technical expertise, quality of products and services, and the broadness of its range. But this is not enough, in a constantly changing and competitive environment we have to offer all this and more. Over the next few years our product range will be dramatically expanded and renewed.

The goal we have set for quality ensures no less than constant progress, as part of GE's company-wide Six Sigma product and service excellence initiative. This applies not only to our products and services but also to our business conduct, where only the highest standards are good enough. We believe that our most important asset is the trust our customers put in us. We earn it by our continuing quest for improvement on every front and our strong commitment to integrity and reliability.

Now on the net !
www.gepowercontrols.com

GE Power Controls

GE Power Controls
East Lancashire Road
Liverpool L10 5 HB

Tel. 0151/524 1122
Fax 0151/524 6247
E-mail: gepcuk@gepc.com

GE Power Controls
Export department
AXXES Business Park
Guldensporenpark 30
B-9820 Merelbeke (Gent)
Belgium

Tel.: +32/9 210 38 11
Fax: +32/9 210 39 20
E-mail: gepcbel@gepc.com