

	Rated		MOTOR		
	Current	Frequency	380/415V	480/500V	575/600V
	A	Hz	kW - hp	kW - hp	kW - hp
ASTAT S - 400V					
QA12P008S	8	50/60	4,0 - 5	-	-
QA12P017S	17	50/60	7,5 - 10	-	-
QA12P022S	22	50/60	11,0 - 15	-	-
QA12P031S	31	50/60	15,0 - 20	-	-
QA12P044S	44	50/60	22,0 - 30	-	-
QA12P058S	58	50/60	30,0 - 40	-	-
ASTAT S - 500V					
QA22P008S	8	50/60	-	5,5 - 7,5	-
QA22P017S	17	50/60	-	11,0 - 15	-
QA22P022S	22	50/60	-	15,0 - 20	-
QA22P031S	31	50/60	-	22,0 - 30	-
QA22P044S	44	50/60	-	30,0 - 40	-
QA22P058S	58	50/60	-	45,0 - 60	-
ASTAT S - 600V					
QA32P008S	8	50/60	-	-	7,5 - 10
QA32P017S	17	50/60	-	-	15,0 - 20
QA32P022S	22	50/60	-	-	22,0 - 30
QA32P031S	31	50/60	-	-	30,0 - 40
QA32P044S	44	50/60	-	-	37,0 - 50
QA32P058S	58	50/60	-	-	55,0 - 75

	Starting		Ramp 1 sec.		Ramp 2 sec.		Ramp 5 sec.	
	Current	Ops./hour	Cycles/hour	Ops./hour	Cycles/hour	Ops./hour	Cycles/hour	
QA_2P008S	8	450	225	210	105	100	50	
	16	210	105	100	50	46	23	
	24	130	65	66	33	28	14	
	28 (*)	108	54	56	28	22	11	
QA_2P017S	17	450	225	210	105	90	45	
	34	210	105	100	50	42	21	
	51	130	65	66	33	26	13	
QA_2P022S	22	450	225	210	105	90	45	
	44	210	105	100	50	42	21	
	66	130	65	66	33	26	13	
QA_2P031S	31	720	360	360	180	140	70	
	62	400	200	210	105	80	40	
	93	276	138	130	65	52	26	
QA_2P044S	44	720	360	360	180	140	70	
	88	400	200	210	105	80	40	
	132	276	138	130	65	52	26	
QA_2P058S	58	720	360	360	180	140	70	
	116	400	200	210	105	80	40	
	174	276	138	130	65	52	26	
	200 (*)	224	112	100	50	44	22	

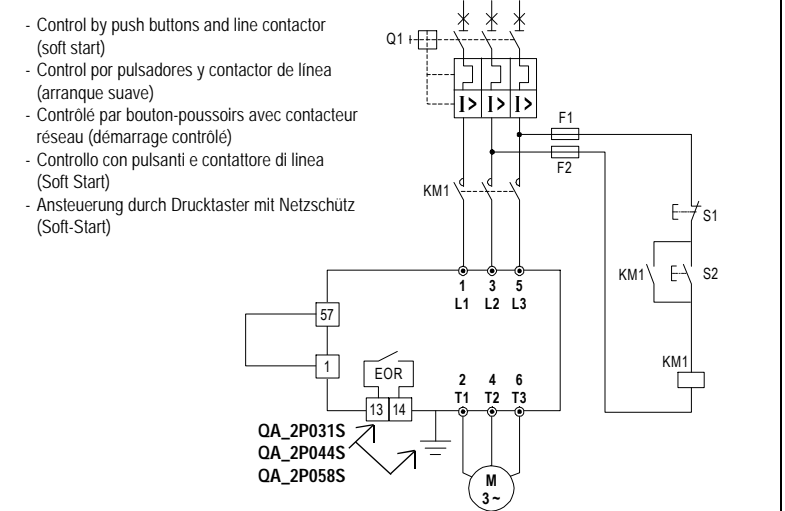
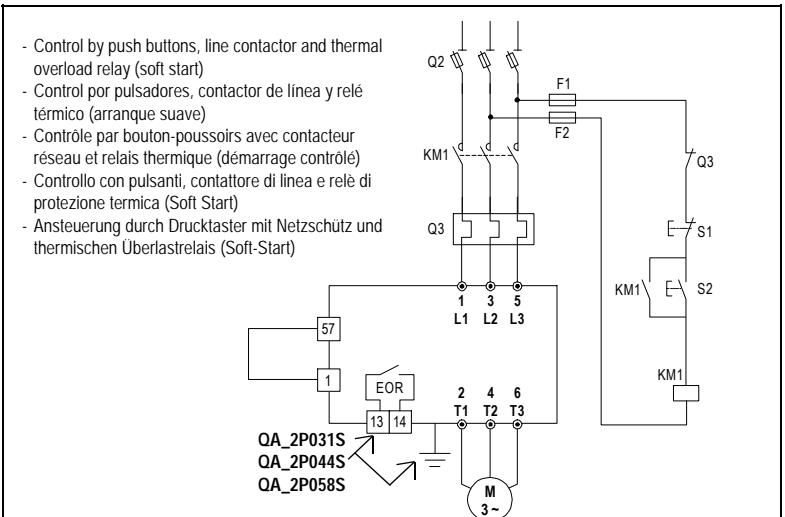
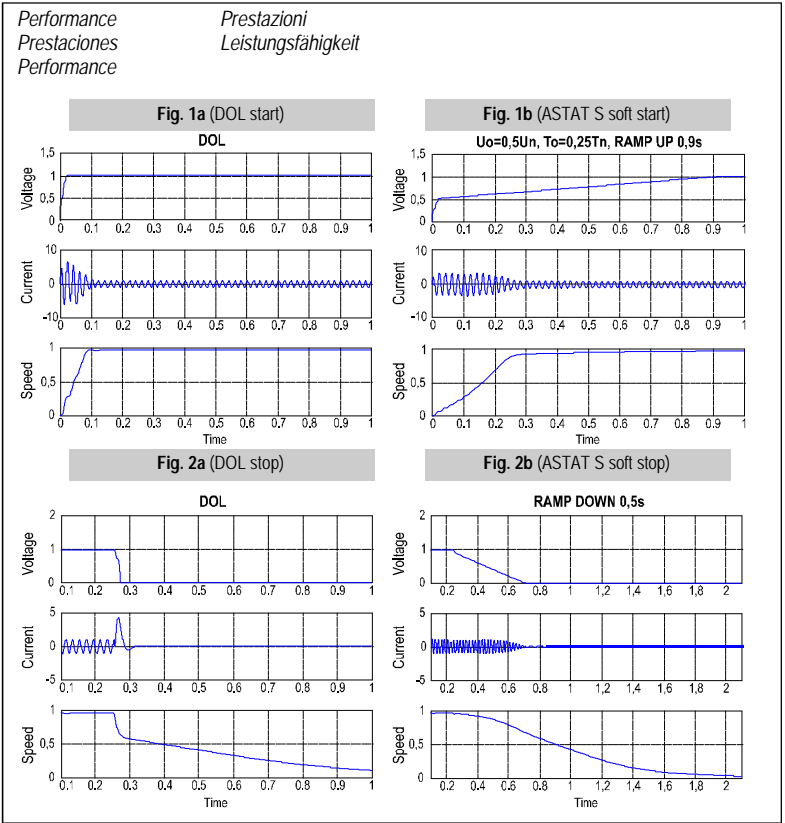
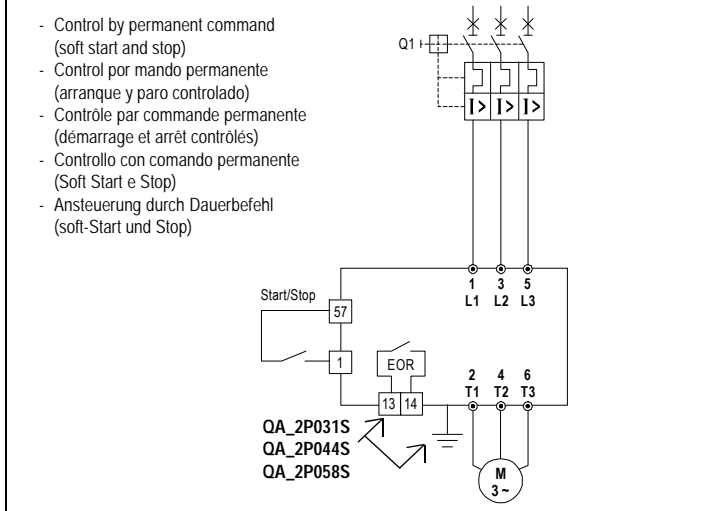

ASTAT S (English)

ASTAT S is compact, easy to operate soft starter, designed for use with standard 3 phase squirrel cage motors. It provides an advanced method of reducing current during motor starting and stopping. ASTAT S will start supplying a reduced voltage to the motor, increasing up to the rated voltage, avoiding so, high currents and generating soft starting and stopping. The motor has to be able to start in a reduced voltage.

INSTALLATION NOTES

Prior to installation
Check that the motor's full load current (FLC) is lower than or equal to your embodiment rated current. (See Table Motors selection).

Mounting
Do not mount the starter near heat sources and ensure the starter is protected from dust, corrosive and explosive atmospheres. Altitude should not exceed 1000m. Above this altitude, derate power 5% each 100m.

Ambient conditions
The starter is rated to operate over a temperature range of 0°C to 40°C (32°F to 104°F). For higher temperatures, derate power 1.2% for each °C, up to 60°C. Storage temperature, -20°C to 70°C (-4 to 158 °F). Non condensed humidity inside the enclosure should not exceed 85%. Operating in pollution ambient degree 3, (IEC-947-1). Protection degree IP20.

Power Factor capacitors
Capacitors must be installed on the line side of the starter, when required and not on the motor side, otherwise damage will occur.

Overload, short circuit and transient protection
The starter and the motor must be protected against overload and short circuits by thermal protection device. When high transients are expected, an external protection should be used.

Connections
Line voltage must be connected to terminals 1L1, 3L2, 5L3. Motor connections to terminals 2T1, 4T2, 6T3. Do not interchange line and motor connections. 1-57 is the start /stop permanent command. 13-14, only for frames 31-44-58 A, end of acceleration output (EOR).

Displays
Green led (ON), indicates supply.
Yellow led (Start/Stop) illuminates upon Start command and during Soft Stopping.
Green led (Run) illuminates upon end of starting, when the internal by pass closes.

MODE OF OPERATION

Initial Voltage
The initial voltage determines the initial torque (the torque is directly proportional to the square of the voltage). A too high setting may cause inrush currents or mechanical shocks. A too low setting may result in prolonged time until the motor begin turning. Range 0-80% Un. (see fig. 1b)*

Ramp up time
The ramp up time determines the time from initial to full voltage. Range 0.5-5 sec. (see fig. 1b)*

Ramp down time
Ramp down time is used for motor soft stop. When Soft Stop is initiated, the starter output voltage is gradually ramped down. At the end of the deceleration time starting/stopping LED will turn off. Depending on the application inertia, once finished the ramp down time, motor may be still turning. (see fig. 2b)*

* fig. 1 & 2, are the real values from a 2,2 kW motor in a conveyor application. For other motor power and application, performing may be different.

Standard starting processes

- Set the front potentiometers as follows:
- Starting torque at 30%.
- Ramp up- time at 2 seconds.
- Connect the start voltage, the Start/Stop LED will illuminate. If the motor starts to turn shortly after the start signal and accelerates to full speed, proceed to 3.
If not, increase the Starting Torque setting until the motor, starts to turn shortly after the start signal. When, upon starting, the inrush current and mechanical shock are to high, decrease Starting Torque setting, and proceed to 3.
- Disconnect the start command and wait until the motor stops.
- Start again to check that the acceleration process to full speed is as required.
- If acceleration time is to quick, increase the ramp-up setting.

Soft stopping
Set the ramp-down potentiometer to 5 seconds and disconnect the start command. The internal by-pass relays open and voltage to the motor will be slowly ramped down.

CAUTION
Installation, operation and maintenance should be in strict accordance with this instruction manual, national codes and good practice. Installation or operation not performed with these instructions will void the manufacturer's warranty.
When main voltage is connected to ASTAT S, even if the start signal is not initiated, full voltage may appear on starter's load terminals. Disconnect all power inputs before wiring or servicing equipment.
This product has been designed for class A equipment. Use of the product in domestic environments may cause radio interference, in which case the user should employ additional mitigation methods.

Rated Operational Voltage*	
QA12P__S	380/415 -15/+10%VACrms 50/60Hz +5/-5 Hz
QA22P__S	480/500 -15/+10%VACrms 50/60Hz +5/-5 Hz
QA32P__S	575/600 -15/+10%VACrms 50/60Hz +5/-5 Hz

Load	Standards
3-phase, 3 wire, squirrel cage motor	
Control specifications	Standards
Ramp up	0.5-5 s CE marking
Ramp down	0.5-5 s
Initial voltage	0-80% Un
Initial torque	0-64% Tn

Environment*	
Operating temperature	0 ~ 40 °C (32 ~ 140 °F)
Storage temperature	-20 ~ 70 °C (-4 ~ 158 °F)
Humidity	up to 80%
Altitude	up to 1000m
Protection degree	IP20

Wiring			
Power terminals	mm ²	AWG	Nm(lb/in.)
QA - 2P008S	1	18	0,4(3,7)
QA - 2P017S	2,5	14	0,4(3,7)
QA - 2P022S	4	12	0,4(3,7)
QA - 2P031S	6	10	0,4(3,7)
QA - 2P044S	10	8	0,8(7)
QA - 2P058S	16	6	1,8(16)



GE Power Controls

ASTAT S

Instructions Manual
Manual de Instrucciones
Manual d'Utilisation
Manuale d'Istruzione
Benutzerhandbuch

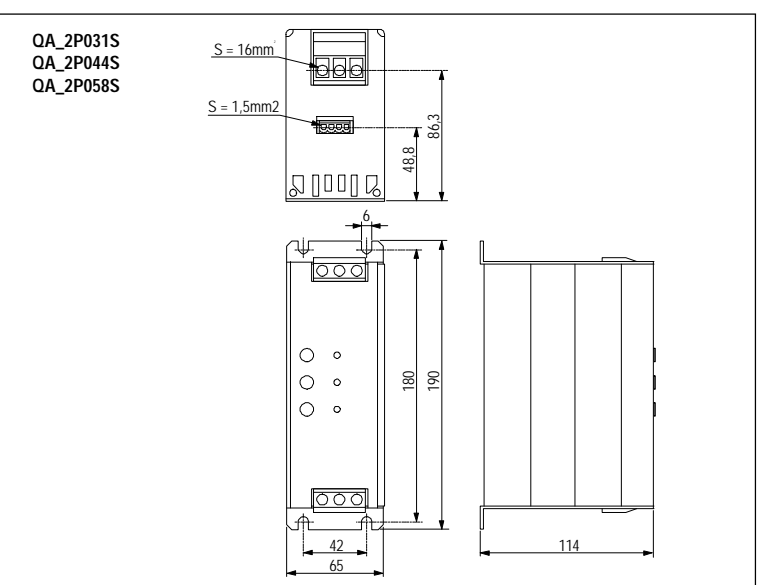
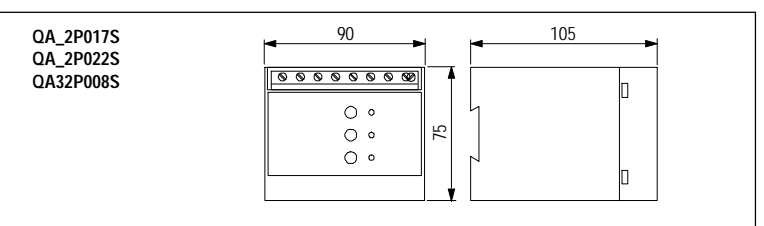
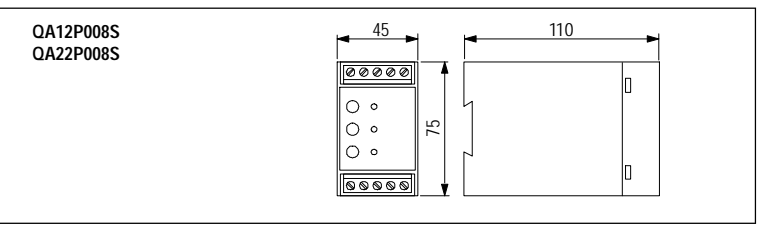

Motor (power)	ASTAT S	Q1	Q2	KM1	Q3	F1-F2	S1-S2-S3
380/415V							
kW	hp	aM fuses					
4	5	QA12P008	GPS1B*AK	10	CL25A	RT A 1N	P9
7,5	10	QA12P017	GPS1B*AN	25	CL25A	RT A 1S	P9
11	15	QA12P022	GPS1B*AP	32	CL25A	RT A 1T	P9
15	20	QA12P031	GPS1B*AR	40	CL04A	RT A 1V	P9
22	30	QA12P044	GPS2B*AT	63	CL06A	RT A 2F	P9
30	40	QA12P058	GPS2B*AU	80	CL07A	RT A 2H	P9